



PRODUCT DATA & SPECIFICATIONS

Bulletin T40-TEHC-PDS-1
Part # 1106702

TEH New "C" Generation
Condensing Units

60
Hz

Indoor/Outdoor
Air-Cooled Hermetic
Condensing Units
1/2 to 5 HP -
High, Medium and Low
Temperature Refrigeration

PRODUCT SUPPORT
 web: t-rp.com/teh
 email: smcu@t-rp.com
 call: 1-844-893-3222 x521

scan:

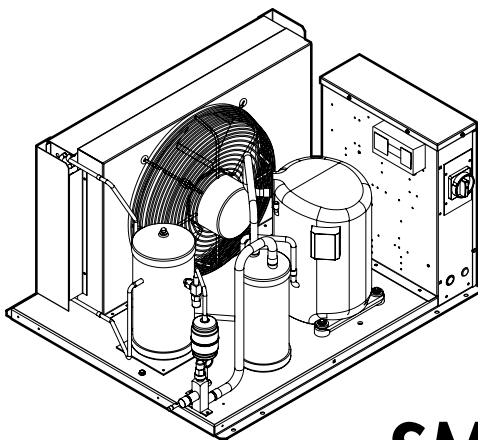

Indoor Unit

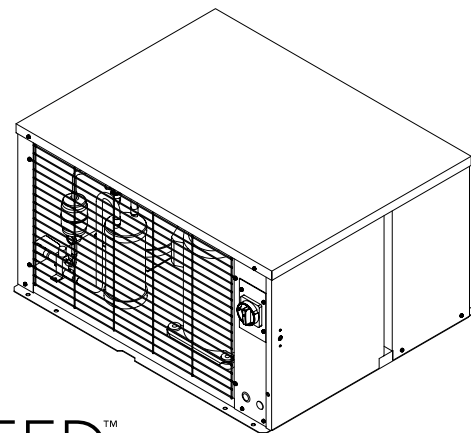

Outdoor Unit

SMARTSPEED™

FAN MOTOR TECHNOLOGY

See Page 4 for details

CONTENTS

	Page
Nomenclature.....	2
Features and Options.....	2 - 3
SMARTSPEED™ Fan Motor Technology	4
Capacity Data (Imperial and <i>Metric</i>).....	5 - 11
Electrical Data.....	12 - 13
Dimensional Data.....	14 - 16
Annual Walk-In Energy Factor (AWEF) Ratings.....	17
Specifications.....	17
Wiring Diagrams.....	18 - 20
Wiring Diagrams - Models with SMARTSPEED™	21
Project Information.....	23
Product Support Resources.....	BACK

NOMENCLATURE

T E H A 010 M 8 - H T3 C - A

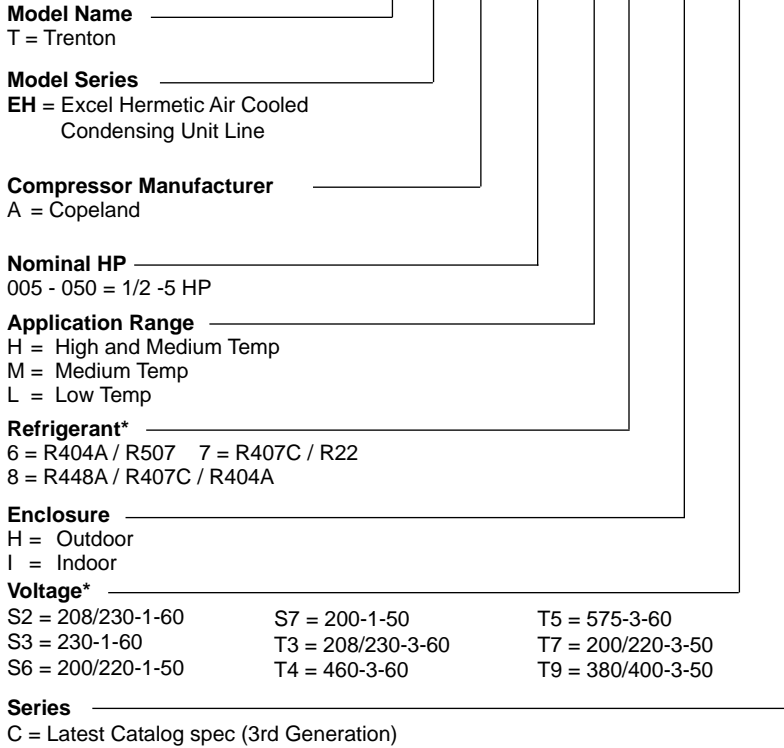

- Optional Feature Packages (Factory Mounted)**
- A = Standard Features (see below)
 - B = Standard Features (see below)
Plus Sealed Liquid Line Filter Drier and Sight Glass
 - C = Standard Features (see below)
Plus Sealed Liquid Line Filter Drier and Sight Glass
Plus Suction Accumulator
Plus Electric Defrost Kit
 - D = Standard Features (see below)
Plus Sealed Liquid Line Filter Drier and Sight Glass
Plus Heated and Insulated Receiver
 - E = Standard Features (see below)
Plus Sealed Liquid Line Filter Drier and Sight Glass
Plus Heated and Insulated Receiver
Plus Suction Accumulator
Plus Electric Defrost Kit
 - F = Standard Features (see below)
Plus Sealed liquid line filter drier and sight glass
Plus Electric Defrost Kit
 - G = Standard Features (see below)
Plus Sealed liquid line filter drier and sight glass
Plus Electric Defrost Kit
Plus Heated and insulated receiver
 - H = Standard Features (see below)
Plus Sealed Liquid Line Filter Drier and Sight Glass
Plus Timeclock
 - J = Standard Features (see below)
Plus Sealed Liquid Line Filter Drier and Sight Glass
Plus Heated and insulated receiver
Plus Suction Accumulator

* subject to compressor availability

STANDARD FEATURES

Indoor Unit:

- Weatherproof electrical control box with compressor contactor and fused control circuit
- Welded-hermetic compressor
- High efficiency enhanced tube and fin condenser design
- Pre-formed piping
- Quiet fan motor operation
- Energy efficient PSC condenser fan motor
- Electrical control panel away from air flow stream
- Wide-open front design, spring latches and handle on 5Hp MT & HT or larger
- Unit leak tested and shipped with helium holding charge
- Painted cabinet
- QuickVac Evacuation and Refrigerant Recovery Valves

- Receiver with fusible plug and liquid shut off valve
- Suction service valve
- Copper tubing secured with cushion clamps
- Fixed high and low pressure control

Outdoor Unit: All Standard Features of Indoor Unit, Plus:

- Painted weather-resistant housing with removable hood
- Flooded head pressure control (non adjustable)
- Crankcase heater

OPTIONAL FEATURE PACKAGES (Factory Mounted)

Package A:

- Standard Features (see pg. 2)

Package B:

- Standard Features (see pg. 2)
- *Plus* Sealed Liquid Line Filter Drier & Sight Glass

Package C:

- Standard Features (see pg. 2)
- *Plus* Sealed Liquid Line Filter Drier & Sight Glass
- *Plus* Suction Accumulator
- *Plus* Electric Defrost Kit

Package D:

- Standard Features (see pg. 2)
- *Plus* Sealed Liquid Line Filter Drier & Sight Glass
- *Plus* Heated and Insulated Receiver

Package E:

- Standard Features (see pg. 2)
- *Plus* Sealed Liquid Line Filter Drier & Sight Glass
- *Plus* Heated and Insulated Receiver
- *Plus* Suction Accumulator
- *Plus* Electric Defrost Kit

Package F:

- Standard Features (see pg. 2)
- *Plus* Sealed liquid line filter drier and sight glass
- *Plus* Electric Defrost Kit

Package G:

- Standard Features (see pg. 2)
- *Plus* Sealed liquid line filter drier and sight glass
- *Plus* Electric Defrost Kit
- *Plus* Heated and insulated receiver

Package H:

- Standard Features (see pg. 2)
- *Plus* Sealed Liquid Line Filter Drier and Sight Glass
- *Plus* Timeclock

Package J:

- Standard Features (see pg. 2)
- *Plus* Sealed Liquid Line Filter Drier and Sight Glass
- *Plus* Heated and insulated receiver
- *Plus* Suction Accumulator

AVAILABLE OPTIONS

- Sealed suction filter
- Suction accumulator
- Suction accumulator with boil-out coil
- Heated and insulated receiver
- Sealed liquid line filter drier and sight glass
- Liquid line solenoid valve with 230-volt coil (shipped loose)
- Compressor circuit breaker
- Compressor time delay relay
- Variable speed EC motors only as head pressure control (see Bulletin T40-HPC-AG or docs.t-rp.com/1101111.pdf for details)
- **SmartSpeed Fan Motor Technology (see page 4)**
- Pump down toggle switch
- Electric defrost kit with mechanical time clock and contactors, as required
- Hoffman variable fan speed control
- Lockout control circuit relay (for liquid solenoid valve)
- Disconnect switch (fused or non-fused)
- Electronic phase / voltage monitor
- Leg kit or air discharge hood

US Patent No.
9,297,567

DESIGN FEATURES



• Available on 1/2 - 22 HP
Hermetic, Scroll or Semi-Hermetic Condensing Units

- No special controls required. No worries about wind or cold climates.
- Ambients above 55°F - EC motor operates at full speed, crankcase heater and heated + insulated receiver disabled from control circuit
- Ambients below 55°F - EC motor operates at low speed, crankcase heater and heated + insulated receiver enabled from control circuit

Condensing Unit EER - Standard Unit vs. SmartSpeed

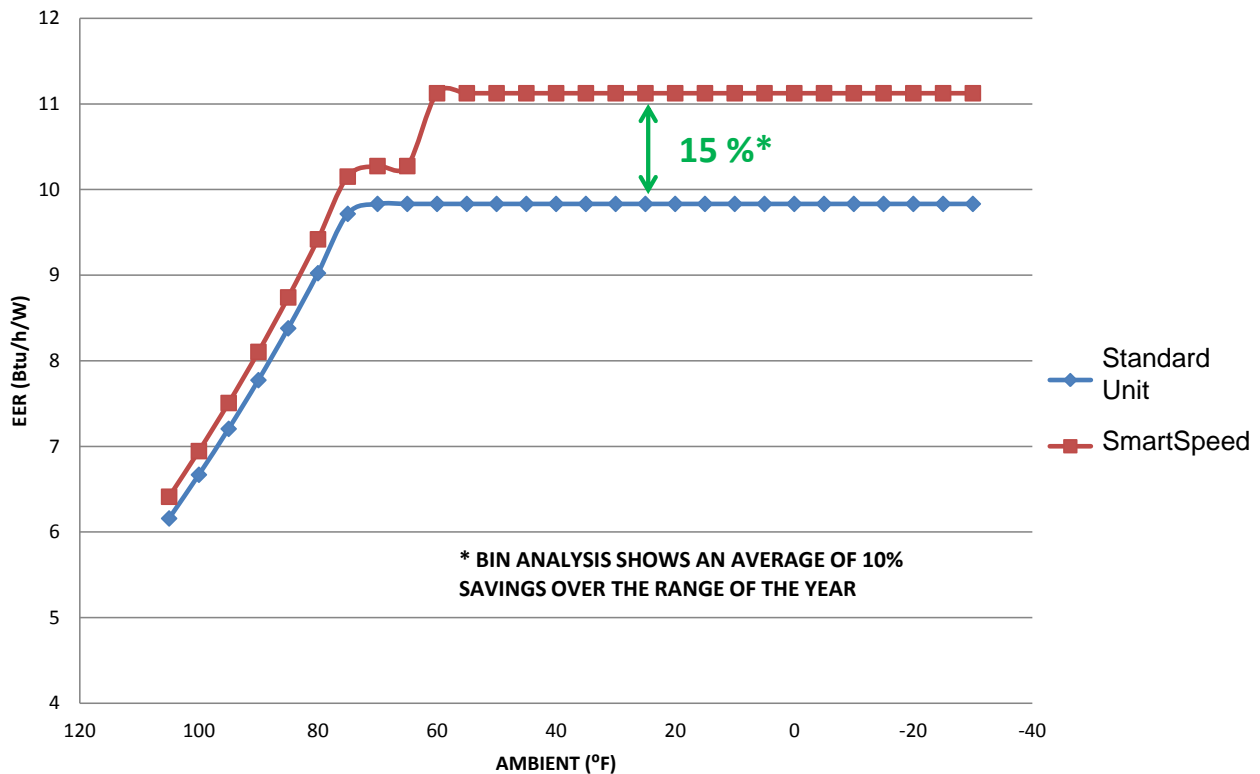

**Refer to
Page 21
For Wiring
Details**

Condensing Unit with SmartSpeed Power Consumption Per Motor		
Chassis Size (see pages 14-16)	Ambients above 55°F. Fan Full Speed. Crankcase and Receiver Heaters Off.	Ambients below 55°F. Fan Low Speed. Crankcase and Receiver Heaters On.
A	102 W	19 W
B	168 W	37 W
C,D	362 W	76 W
E	630 W	152 W
F	1180 W	240 W

CAPACITY DATA - R448A
MEDIUM TEMPERATURE

MODEL	SATURATED SUCTION TEMPERATURE		CAPACITY BTU/H (WATTS) R448A AMBIENT TEMPERATURE °F (°C)										
	° F	° C	80 (26.6)	85 (29.4)	90 (32.2)	95 (35.0)	100 (37.8)	105 (40.6)	110 (43.3)				
TEHA006M8 Compressor Model RST45C1E	30	(-1.1)	7740 (2270)	7430 (2180)	7110 (2080)	6800 (1990)	6490 (1900)	6180 (1810)	5880 (1720)				
	25	(-3.9)	6920 (2030)	6640 (1950)	6360 (1860)	6080 (1780)	5800 (1700)	5510 (1610)	5240 (1540)				
	20	(-6.7)	6160 (1810)	5910 (1730)	5660 (1660)	5410 (1590)	5150 (1510)	4890 (1430)	4650 (1360)				
	15	(-9.4)	5460 (1600)	5240 (1540)	5010 (1470)	4790 (1400)	4570 (1340)	4340 (1270)	4120 (1210)				
	10	(-12.2)	4820 (1410)	4620 (1350)	4420 (1300)	4220 (1240)	4020 (1180)	3820 (1120)	3610 (1060)				
	5	(-15.0)	4230 (1240)	4050 (1190)	3890 (1140)	3710 (1090)	3530 (1030)	3350 (980)	3170 (930)				
	0	(-17.8)	3710 (1090)	3550 (1040)	3390 (990)	3240 (950)	3090 (910)	2930 (860)	2770 (810)				
-5	(-20.6)	3050 (890)	2940 (860)	2840 (830)	2730 (800)	2520 (740)	2420 (710)	-	-				
-10	(-23.3)	2630 (770)	2520 (740)	2420 (710)	2310 (680)	2210 (650)	-	-	-				
TEHA008M8 Compressor Model RST55C1E	30	(-1.1)	9030 (2650)	8650 (2540)	8270 (2420)	7900 (2320)	7520 (2200)	7140 (2090)	6770 (1980)				
	25	(-3.9)	8100 (2370)	7750 (2270)	7410 (2170)	7070 (2070)	6740 (1980)	6410 (1880)	6080 (1780)				
	20	(-6.7)	7220 (2120)	6910 (2030)	6620 (1940)	6320 (1850)	6020 (1760)	5720 (1680)	5430 (1590)				
	15	(-9.4)	6430 (1880)	6150 (1800)	5890 (1730)	5630 (1650)	5360 (1570)	5090 (1490)	4830 (1420)				
	10	(-12.2)	5690 (1670)	5460 (1600)	5220 (1530)	4990 (1460)	4760 (1400)	4530 (1330)	4280 (1250)				
	5	(-15.0)	5030 (1470)	4820 (1410)	4610 (1350)	4410 (1290)	4200 (1230)	3990 (1170)	3790 (1110)				
	0	(-17.8)	4430 (1300)	4240 (1240)	4050 (1190)	3890 (1140)	3700 (1080)	3520 (1030)	3330 (980)				
-5	(-20.6)	3680 (1080)	3570 (1050)	3360 (980)	3260 (960)	3050 (890)	2940 (860)	-	-				
-10	(-23.3)	3260 (960)	3150 (920)	2940 (860)	2840 (830)	-	-	-	-				
TEHA009M8 Compressor Model RST64C1E	30	(-1.1)	10600 (3110)	10170 (2980)	9790 (2870)	9390 (2750)	8990 (2630)	8590 (2520)	8190 (2400)				
	25	(-3.9)	9530 (2790)	9180 (2690)	8820 (2580)	8460 (2480)	8100 (2370)	7740 (2270)	7380 (2160)				
	20	(-6.7)	8580 (2510)	8260 (2420)	7940 (2330)	7610 (2230)	7290 (2140)	6950 (2040)	6640 (1950)				
	15	(-9.4)	7700 (2260)	7410 (2170)	7120 (2090)	6840 (2000)	6530 (1910)	6250 (1830)	5950 (1740)				
	10	(-12.2)	6890 (2020)	6630 (1940)	6370 (1870)	6110 (1790)	5850 (1710)	5590 (1640)	5330 (1560)				
	5	(-15.0)	6140 (1800)	5910 (1730)	5680 (1660)	5450 (1600)	5220 (1530)	4980 (1460)	4760 (1400)				
	0	(-17.8)	5450 (1600)	5250 (1540)	5040 (1480)	4850 (1420)	4640 (1360)	4430 (1300)	-	-			
-5	(-20.6)	4940 (1450)	4730 (1390)	4520 (1320)	4410 (1290)	4200 (1230)	-	-	-				
-10	(-23.3)	4310 (1260)	4200 (1230)	3990 (1170)	-	-	-	-	-				
TEHA010M8 Compressor Model RST70C1E	30	(-1.1)	11300 (3310)	10900 (3190)	10500 (3080)	10090 (2960)	9650 (2830)	9220 (2700)	8780 (2570)				
	25	(-3.9)	10370 (3040)	9990 (2930)	9600 (2810)	9190 (2690)	8790 (2580)	8390 (2460)	7980 (2340)				
	20	(-6.7)	9430 (2760)	9060 (2660)	8690 (2550)	8340 (2440)	7960 (2330)	7580 (2220)	7210 (2110)				
	15	(-9.4)	8520 (2500)	8180 (2400)	7850 (2300)	7510 (2200)	7170 (2100)	6830 (2000)	6480 (1900)				
	10	(-12.2)	7650 (2240)	7350 (2150)	7050 (2070)	6740 (1980)	6420 (1880)	6100 (1790)	5780 (1690)				
	5	(-15.0)	6840 (2000)	6560 (1920)	6290 (1840)	6000 (1760)	5700 (1670)	5420 (1590)	5110 (1500)				
	0	(-17.8)	6080 (1780)	5820 (1710)	5550 (1630)	5290 (1550)	5030 (1470)	4770 (1400)	-	-			
-5	(-20.6)	5150 (1510)	4940 (1450)	4620 (1350)	4410 (1290)	4200 (1230)	-	-	-				
-10	(-23.3)	4520 (1320)	4310 (1260)	4100 (1200)	3890 (1140)	-	-	-	-				
TEHA011M8 Compressor Model RST80C1E	30	(-1.1)	12900 (3780)	12500 (3660)	12100 (3550)	11600 (3400)	11000 (3220)	10600 (3110)	10080 (2950)				
	25	(-3.9)	11800 (3460)	11300 (3310)	10900 (3190)	10500 (3080)	10060 (2950)	9600 (2810)	9140 (2680)				
	20	(-6.7)	10700 (3140)	10340 (3030)	9930 (2910)	9520 (2790)	9100 (2670)	8660 (2540)	8230 (2410)				
	15	(-9.4)	9690 (2840)	9330 (2730)	8950 (2620)	8570 (2510)	8180 (2400)	7770 (2280)	7380 (2160)				
	10	(-12.2)	8700 (2550)	8370 (2450)	8020 (2350)	7670 (2250)	7300 (2140)	6940 (2030)	6560 (1920)				
	5	(-15.0)	7770 (2280)	7460 (2190)	7140 (2090)	6800 (1990)	6470 (1900)	6130 (1800)	5790 (1700)				
	0	(-17.8)	6900 (2020)	6600 (1930)	6300 (1850)	6010 (1760)	5690 (1670)	5390 (1580)	-	-			
-5	(-20.6)	5990 (1760)	5780 (1690)	5460 (1600)	5250 (1540)	4940 (1450)	-	-	-				
-10	(-23.3)	5250 (1540)	5040 (1480)	4730 (1390)	4520 (1320)	-	-	-	-				
TEHA013M8 Compressor Model RST97C1E	30	(-1.1)	15000 (4400)	14500 (4250)	14000 (4100)	13400 (3930)	12800 (3750)	12300 (3600)	11800 (3460)				
	25	(-3.9)	13800 (4040)	13200 (3870)	12700 (3720)	12300 (3600)	11800 (3460)	11200 (3280)	10700 (3140)				
	20	(-6.7)	12500 (3660)	12100 (3550)	11600 (3400)	11100 (3250)	10700 (3140)	10200 (2990)	9720 (2850)				
	15	(-9.4)	11300 (3310)	10900 (3190)	10500 (3080)	10060 (2950)	9630 (2820)	9200 (2700)	8760 (2570)				
	10	(-12.2)	10190 (2990)	9800 (2870)	9420 (2760)	9020 (2640)	8630 (2530)	8230 (2410)	7830 (2290)				
	5	(-15.0)	9100 (2670)	8760 (2570)	8400 (2460)	8040 (2360)	7680 (2250)	7310 (2140)	6940 (2030)				
	0	(-17.8)	8090 (2370)	7780 (2280)	7440 (2180)	7120 (2090)	6780 (1990)	6440 (1890)	6100 (1790)				
-5	(-20.6)	6930 (2030)	6620 (1940)	6410 (1880)	6090 (1780)	5780 (1690)	5460 (1600)	-	-				
-10	(-23.3)	6090 (1780)	5780 (1690)	5570 (1630)	5250 (1540)	-	-	-	-				

NOTES:

- Above ratings are based on mean temperature.
- To convert to dew point ratings, use 0.95 multiplier.
- For R449A, use R448A data.

CAPACITY DATA - R407C
MEDIUM TEMPERATURE

MODEL TEH	SATURATED SUCTION TEMPERATURE		CAPACITY BTU/H (WATTS) R407C AMBIENT TEMPERATURE °F (°C)							
	°F	°C	80 (26.6)	85 (29.4)	90 (32.2)	95 (35.0)	100 (37.8)	105 (40.6)	110 (43.3)	
TEHA006M8 Compressor Model RST45C1E	45 (7.2)		10010 (2930)	9630 (2820)	9250 (2710)	8860 (2600)	8490 (2490)	8120 (2380)	7730 (2270)	
	40 (4.4)		9070 (2660)	8740 (2560)	8380 (2460)	8030 (2350)	7690 (2250)	7340 (2150)	7000 (2050)	
	35 (1.7)		8180 (2400)	7880 (2310)	7550 (2210)	7250 (2120)	6920 (2030)	6620 (1940)	6310 (1850)	
	30 (-1.1)		7340 (2150)	7060 (2070)	6770 (1980)	6490 (1900)	6210 (1820)	5930 (1740)	5650 (1660)	
	25 (-3.9)		6550 (1920)	6300 (1850)	6040 (1770)	5790 (1700)	5530 (1620)	5280 (1550)	5030 (1470)	
	20 (-6.7)		5810 (1700)	5590 (1640)	5360 (1570)	5120 (1500)	4890 (1430)	4670 (1370)	4450 (1300)	
	15 (-9.4)		5130 (1500)	4940 (1450)	4730 (1390)	4530 (1330)	4330 (1270)	4120 (1210)	3920 (1150)	
10 (-12.2)		4540 (1330)	4350 (1270)	4160 (1220)	3970 (1160)	3790 (1110)	3600 (1060)	3430 (1010)		
TEHA008M8 Compressor Model RST55C1E	45 (7.2)		11800 (3460)	11200 (3280)	10800 (3170)	10370 (3040)	9910 (2900)	9460 (2770)	8990 (2630)	
	40 (4.4)		10600 (3110)	10230 (3000)	9830 (2880)	9420 (2760)	9000 (2640)	8580 (2510)	8150 (2390)	
	35 (1.7)		9620 (2820)	9250 (2710)	8870 (2600)	8510 (2490)	8130 (2380)	7750 (2270)	7360 (2160)	
	30 (-1.1)		8650 (2540)	8330 (2440)	7990 (2340)	7650 (2240)	7310 (2140)	6970 (2040)	6630 (1940)	
	25 (-3.9)		7750 (2270)	7460 (2190)	7150 (2100)	6860 (2010)	6550 (1920)	6250 (1830)	5930 (1740)	
	20 (-6.7)		6910 (2030)	6650 (1950)	6380 (1870)	6120 (1790)	5850 (1710)	5570 (1630)	5290 (1550)	
	15 (-9.4)		6140 (1800)	5900 (1730)	5670 (1660)	5430 (1590)	5200 (1520)	4940 (1450)	4690 (1370)	
10 (-12.2)		5420 (1590)	5220 (1530)	5010 (1470)	4800 (1410)	4580 (1340)	4370 (1280)	4150 (1220)		
TEHA009M8 Compressor Model RST64C1E	45 (7.2)		13900 (4070)	13300 (3900)	12800 (3750)	12200 (3580)	11700 (3430)	11100 (3250)	10500 (3080)	
	40 (4.4)		12600 (3690)	12200 (3580)	11700 (3430)	11100 (3250)	10600 (3110)	10120 (2970)	9610 (2820)	
	35 (1.7)		11400 (3340)	11000 (3220)	10600 (3110)	10110 (2960)	9650 (2830)	9190 (2690)	8720 (2560)	
	30 (-1.1)		10360 (3040)	9960 (2920)	9560 (2800)	9140 (2680)	8720 (2560)	8300 (2430)	7880 (2310)	
	25 (-3.9)		9320 (2730)	8960 (2630)	8590 (2520)	8220 (2410)	7840 (2300)	7470 (2190)	7090 (2080)	
	20 (-6.7)		8340 (2440)	8010 (2350)	7690 (2250)	7350 (2150)	7010 (2050)	6680 (1960)	6340 (1860)	
	15 (-9.4)		7420 (2170)	7140 (2090)	6850 (2010)	6540 (1920)	6250 (1830)	5950 (1740)	5650 (1660)	
10 (-12.2)		6570 (1930)	6310 (1850)	6060 (1780)	5800 (1700)	5530 (1620)	5260 (1540)	5000 (1470)		
TEHA010M8 Compressor Model RST70C1E	45 (7.2)		14800 (4340)	14300 (4190)	13700 (4020)	13100 (3840)	12500 (3660)	12000 (3520)	11300 (3310)	
	40 (4.4)		13500 (3960)	13000 (3810)	12500 (3660)	12000 (3520)	11400 (3340)	10900 (3190)	10350 (3030)	
	35 (1.7)		12300 (3600)	11800 (3460)	11300 (3310)	10900 (3190)	10400 (3050)	9920 (2910)	9430 (2760)	
	30 (-1.1)		11100 (3250)	10700 (3140)	10280 (3010)	9860 (2890)	9430 (2760)	9000 (2640)	8550 (2510)	
	25 (-3.9)		10020 (2940)	9660 (2830)	9280 (2720)	8890 (2610)	8520 (2500)	8130 (2380)	7730 (2270)	
	20 (-6.7)		9010 (2640)	8670 (2540)	8350 (2450)	8000 (2340)	7650 (2240)	7310 (2140)	6950 (2040)	
	15 (-9.4)		8070 (2370)	7760 (2270)	7470 (2190)	7150 (2100)	6850 (2010)	6530 (1910)	6210 (1820)	
10 (-12.2)		7180 (2100)	6900 (2020)	6630 (1940)	6350 (1860)	6080 (1780)	5790 (1700)	5500 (1610)		
TEHA011M8 Compressor Model RST80C1E	45 (7.2)		17000 (4980)	16400 (4810)	15800 (4630)	15100 (4430)	14500 (4250)	13800 (4040)	13100 (3840)	
	40 (4.4)		15500 (4540)	14900 (4370)	14400 (4220)	13800 (4040)	13100 (3840)	12600 (3690)	12000 (3520)	
	35 (1.7)		14100 (4130)	13500 (3960)	13000 (3810)	12500 (3660)	12000 (3520)	11400 (3340)	10800 (3170)	
	30 (-1.1)		12700 (3720)	12300 (3600)	11800 (3460)	11300 (3310)	10800 (3170)	10330 (3030)	9820 (2880)	
	25 (-3.9)		11400 (3340)	11000 (3220)	10600 (3110)	10200 (2990)	9770 (2860)	9320 (2730)	8860 (2600)	
	20 (-6.7)		10320 (3020)	9930 (2910)	9540 (2800)	9160 (2680)	8770 (2570)	8370 (2450)	7960 (2330)	
	15 (-9.4)		9230 (2710)	8880 (2600)	8540 (2500)	8180 (2400)	7830 (2290)	7480 (2190)	7110 (2080)	
10 (-12.2)		8200 (2400)	7890 (2310)	7570 (2220)	7260 (2130)	6940 (2030)	6620 (1940)	6290 (1840)		
TEHA013M8 Compressor Model RST97C1E	45 (7.2)		20300 (5950)	19500 (5710)	18800 (5510)	18100 (5300)	17200 (5040)	16500 (4840)	15800 (4630)	
	40 (4.4)		18400 (5390)	17700 (5190)	17000 (4980)	16400 (4810)	15600 (4570)	15000 (4400)	14300 (4190)	
	35 (1.7)		16600 (4860)	16100 (4720)	15400 (4510)	14800 (4340)	14200 (4160)	13500 (3960)	12900 (3780)	
	30 (-1.1)		15000 (4400)	14500 (4250)	13900 (4070)	13300 (3900)	12800 (3750)	12200 (3580)	11700 (3430)	
	25 (-3.9)		13400 (3930)	13000 (3810)	12500 (3660)	12000 (3520)	11600 (3400)	11000 (3220)	10480 (3070)	
	20 (-6.7)		12100 (3550)	11700 (3430)	11200 (3280)	10700 (3140)	10300 (3020)	9850 (2890)	9390 (2750)	
	15 (-9.4)		10800 (3170)	10370 (3040)	9980 (2920)	9590 (2810)	9180 (2690)	8770 (2570)	8360 (2450)	
10 (-12.2)		9570 (2800)	9210 (2700)	8850 (2590)	8490 (2490)	8130 (2380)	7760 (2270)	7380 (2160)		

NOTES: - Above ratings are based on mean temperature.
- To convert to dew point ratings, use 0.95 multiplier.

CAPACITY DATA - R404A R507
MEDIUM TEMPERATURE

MODEL TEH	SATURATED SUCTION TEMPERATURE		CAPACITY BTU/H (WATTS) R404A R507								AMBIENT TEMPERATURE °F (°C)	
	° F	° C	80 (26.6)	85 (29.4)	90 (32.2)	95 (35.0)	100 (37.8)	105 (40.6)	110 (43.3)			
TEHA006M8 Compressor Model RST45C1E*	30	(-1.1)	7970 (2335)	7620 (2233)	7260 (2127)	6890 (2019)	6520 (1910)	6130 (1796)	5740 (1682)			
	25	(-3.9)	7290 (2136)	6970 (2042)	6650 (1948)	6310 (1849)	5960 (1746)	5620 (1647)	5260 (1541)			
	20	(-6.7)	6650 (1948)	6350 (1861)	6060 (1776)	5750 (1685)	5450 (1597)	5120 (1500)	4810 (1409)			
	15	(-9.4)	6040 (1770)	5780 (1694)	5500 (1612)	5230 (1532)	4950 (1450)	4660 (1365)	4370 (1280)			
	10	(-12.2)	5450 (1597)	5220 (1529)	4970 (1456)	4730 (1386)	4470 (1310)	4210 (1234)	3950 (1157)			
	5	(-15.0)	4890 (1433)	4680 (1371)	4460 (1307)	4240 (1242)	4010 (1175)	3780 (1108)	3540 (1037)			
	0	(-17.8)	4370 (1280)	4170 (1222)	3970 (1163)	3770 (1105)	3570 (1046)	3350 (982)	3140 (920)			
	-5	(-20.6)	3670 (1075)	3510 (1028)	3340 (979)	3160 (926)	2980 (873)	2800 (820)	2620 (768)			
-10	(-23.3)	3210 (941)	3060 (897)	2900 (850)	2740 (803)	2580 (756)	2420 (709)	2260 (662)				
TEHA008M8 Compressor Model RST55C1E*	30	(-1.1)	9400 (2754)	8930 (2616)	8450 (2476)	7990 (2341)	7520 (2203)	7060 (2069)	6600 (1934)			
	25	(-3.9)	8650 (2534)	8210 (2406)	7770 (2277)	7340 (2151)	6900 (2022)	6470 (1896)	6050 (1773)			
	20	(-6.7)	7930 (2323)	7520 (2203)	7110 (2083)	6700 (1963)	6300 (1846)	5900 (1729)	5500 (1612)			
	15	(-9.4)	7220 (2115)	6850 (2007)	6470 (1896)	6090 (1784)	5720 (1676)	5360 (1570)	4990 (1462)			
	10	(-12.2)	6550 (1919)	6210 (1820)	5860 (1717)	5510 (1614)	5170 (1515)	4830 (1415)	4490 (1316)			
	5	(-15.0)	5910 (1732)	5600 (1641)	5270 (1544)	4960 (1453)	4640 (1360)	4330 (1269)	4020 (1178)			
	0	(-17.8)	5300 (1553)	5020 (1471)	4730 (1386)	4430 (1298)	4150 (1216)	3860 (1131)	3590 (1052)			
	-5	(-20.6)	4510 (1321)	4260 (1248)	4010 (1175)	3760 (1102)	3510 (1028)	3270 (958)	3030 (888)			
-10	(-23.3)	4000 (1172)	3780 (1108)	3560 (1043)	3330 (976)	3110 (911)	2890 (847)	2680 (785)				
TEHA009M8 Compressor Model RST64C1E*	30	(-1.1)	10500 (3080)	10100 (2960)	9640 (2830)	9200 (2700)	8730 (2560)	8260 (2420)	7790 (2280)			
	25	(-3.9)	9720 (2850)	9330 (2730)	8910 (2610)	8500 (2490)	8080 (2370)	7650 (2240)	7220 (2120)			
	20	(-6.7)	8940 (2620)	8580 (2510)	8210 (2410)	7830 (2290)	7440 (2180)	7050 (2070)	6640 (1950)			
	15	(-9.4)	8190 (2400)	7860 (2300)	7520 (2200)	7170 (2100)	6800 (1990)	6440 (1890)	6080 (1780)			
	10	(-12.2)	7460 (2190)	7160 (2100)	6830 (2000)	6510 (1910)	6190 (1810)	5860 (1720)	5530 (1620)			
	5	(-15.0)	6740 (1980)	6460 (1890)	6180 (1810)	5890 (1730)	5590 (1640)	5290 (1550)	4990 (1460)			
	0	(-17.8)	6070 (1780)	5810 (1700)	5550 (1630)	5280 (1550)	5000 (1470)	4730 (1390)	4470 (1310)			
	-5	(-20.6)	5420 (1590)	5180 (1520)	4930 (1440)	4690 (1370)	4450 (1300)	4210 (1230)	3970 (1160)			
-10	(-23.3)	4790 (1400)	4580 (1340)	4360 (1280)	4140 (1210)	3920 (1150)	3700 (1080)	3490 (1020)				
TEHA010M8 Compressor Model RST70C1E	30	(-1.1)	11600 (3400)	11100 (3253)	10600 (3107)	10100 (2960)	9620 (2819)	9120 (2673)	8610 (2523)			
	25	(-3.9)	10700 (3136)	10200 (2989)	9790 (2869)	9350 (2740)	8880 (2602)	8430 (2471)	7960 (2333)			
	20	(-6.7)	9790 (2869)	9390 (2752)	8990 (2635)	8580 (2515)	8160 (2391)	7740 (2268)	7250 (2125)			
	15	(-9.4)	8940 (2620)	8580 (2515)	8200 (2403)	7770 (2277)	7390 (2166)	7000 (2051)	6600 (1934)			
	10	(-12.2)	8070 (2365)	7740 (2268)	7400 (2169)	7060 (2069)	6710 (1966)	6340 (1858)	5990 (1755)			
	5	(-15.0)	7280 (2134)	6970 (2043)	6670 (1955)	6350 (1861)	6030 (1767)	5700 (1670)	5380 (1577)			
	0	(-17.8)	6510 (1908)	6240 (1829)	5950 (1744)	5670 (1662)	5330 (1562)	5040 (1477)	4740 (1389)			
	-5	(-20.6)	5490 (1609)	5250 (1539)	5000 (1465)	4750 (1392)	4490 (1316)	4230 (1240)	3960 (1161)			
-10	(-23.3)	4840 (1418)	4620 (1354)	4390 (1287)	4160 (1219)	3930 (1152)	3690 (1081)	3440 (1008)				
TEHA011M8 Compressor Model RST80C1E	30	(-1.1)	13300 (3900)	12800 (3750)	12200 (3580)	11600 (3400)	11100 (3250)	10500 (3080)	9890 (2900)			
	25	(-3.9)	12200 (3580)	11700 (3430)	11200 (3280)	10700 (3140)	10200 (2990)	9630 (2820)	9060 (2660)			
	20	(-6.7)	11200 (3280)	10800 (3170)	10300 (3020)	9820 (2880)	9310 (2730)	8800 (2580)	8280 (2430)			
	15	(-9.4)	10300 (3020)	9840 (2880)	9390 (2750)	8940 (2620)	8480 (2490)	8000 (2340)	7520 (2200)			
	10	(-12.2)	9330 (2730)	8940 (2620)	8530 (2500)	8110 (2380)	7670 (2250)	7240 (2120)	6800 (1990)			
	5	(-15.0)	8440 (2470)	8080 (2370)	7690 (2250)	7310 (2140)	6910 (2030)	6510 (1910)	6110 (1790)			
	0	(-17.8)	7590 (2220)	7250 (2120)	6910 (2030)	6550 (1920)	6190 (1810)	5820 (1710)	5460 (1600)			
	-5	(-20.6)	6600 (1930)	6300 (1850)	6000 (1760)	5700 (1670)	5300 (1550)	5000 (1470)	4700 (1380)			
-10	(-23.3)	5900 (1730)	5600 (1640)	5300 (1550)	5000 (1470)	4700 (1380)	4400 (1290)	4100 (1200)				
TEHA013M8 Compressor Model RST97C1E	30	(-1.1)	15600 (4570)	15000 (4400)	14400 (4220)	13800 (4040)	13100 (3840)	12400 (3630)	11700 (3430)			
	25	(-3.9)	14400 (4220)	13900 (4070)	13300 (3900)	12700 (3720)	12100 (3550)	11500 (3370)	10800 (3170)			
	20	(-6.7)	13200 (3870)	12700 (3720)	12200 (3580)	11700 (3430)	11100 (3250)	10500 (3080)	9930 (2910)			
	15	(-9.4)	12100 (3550)	11600 (3400)	11100 (3250)	10600 (3110)	10100 (2960)	9580 (2810)	9030 (2650)			
	10	(-12.2)	11000 (3220)	10500 (3080)	10100 (2960)	9630 (2820)	9160 (2680)	8660 (2540)	8170 (2390)			
	5	(-15.0)	9890 (2900)	9500 (2780)	9090 (2660)	8660 (2540)	8230 (2410)	7780 (2280)	7320 (2150)			
	0	(-17.8)	8860 (2600)	8510 (2490)	8130 (2380)	7740 (2270)	7330 (2150)	6920 (2030)	6510 (1910)			
	-5	(-20.6)	7700 (2260)	7300 (2140)	7000 (2050)	6700 (1960)	6300 (1850)	5900 (1730)	5600 (1640)			
-10	(-23.3)	6800 (1990)	6500 (1900)	6200 (1820)	5900 (1730)	5500 (1610)	5200 (1520)	4900 (1440)				

--- Outside Operating Range † Max 40°F RGT * Not suitable for use with R-507

table continues on next page >>>

CAPACITY DATA - R404A R507
MEDIUM TEMPERATURE (cont'd)

MODEL TEH	SATURATED SUCTION TEMPERATURE		CAPACITY BTU/H (WATTS)					AMBIENT TEMPERATURE °F (°C)				
	° F	° C	80 (26.6)	85 (29.4)	90 (32.2)	95 (35.0)	100 (37.8)	105 (40.6)	110 (43.3)			
TEHA015M6 Compressor Model CS10K6E	30 (-1.1)		20200 (5920)	19000 (5570)	17900 (5250)	16700 (4890)	15600 (4570)	14400 (4220)	13300 (3900)			
	25 (-3.9)		18400 (5390)	17300 (5070)	16300 (4780)	15200 (4450)	14100 (4130)	13100 (3840)	12100 (3550)			
	20 (-6.7)		16600 (4860)	15700 (4600)	14700 (4310)	13700 (4020)	12700 (3720)	11800 (3460)	10800 (3170)			
	15 (-9.4)		14900 (4370)	14000 (4100)	13100 (3840)	12200 (3580)	11300 (3310)	10500 (3080)	9590 (2810)			
	10 (-12.2)		13200 (3870)	12400 (3630)	11600 (3400)	10800 (3170)	9990 (2930)	9180 (2690)	8380 (2460)			
	5 (-15.0)		11600 (3400)	10900 (3190)	10100 (2960)	9400 (2750)	8660 (2540)	7930 (2320)	7200 (2110)			
	0 (-17.8)		10100 (2960)	9400 (2750)	8730 (2560)	8060 (2360)	7390 (2170)	6730 (1970)	6070 (1780)			
-5 (-20.6)		8180 (2400)	7600 (2230)	7030 (2060)	6460 (1890)	5600 (1640)	5320 (1560)	4740 (1390)				
-10 (-23.3)		6890 (2020)	6380 (1870)	5850 (1710)	5350 (1570)	4830 (1420)	4310 (1260)	3790 (1110)				
TEHA020M6 Compressor Model CS12K6E	30 (-1.1)		23000 (6740)	21800 (6390)	20500 (6010)	19300 (5660)	18100 (5300)	16800 (4920)	15600 (4570)			
	25 (-3.9)		20800 (6100)	19700 (5770)	18500 (5420)	17400 (5100)	16200 (4750)	15100 (4430)	13900 (4070)			
	20 (-6.7)		18800 (5510)	17700 (5190)	16600 (4860)	15600 (4570)	14500 (4250)	13500 (3960)	12400 (3630)			
	15 (-9.4)		16800 (4920)	15800 (4630)	14900 (4370)	13900 (4070)	12900 (3780)	11900 (3490)	11000 (3220)			
	10 (-12.2)		15000 (4400)	14100 (4130)	13200 (3870)	12300 (3600)	11400 (3340)	10500 (3080)	9610 (2820)			
	5 (-15.0)		13300 (3900)	12400 (3630)	11600 (3400)	10700 (3140)	9920 (2910)	9120 (2670)	8320 (2440)			
	0 (-17.8)		11600 (3400)	10800 (3170)	10100 (2960)	9300 (2730)	8560 (2510)	7830 (2290)	7110 (2080)			
-5 (-20.6)		9600 (2810)	8860 (2600)	8200 (2400)	7540 (2210)	6910 (2030)	6270 (1840)	5650 (1660)				
-10 (-23.3)		8170 (2390)	7520 (2200)	6910 (2030)	6310 (1850)	5730 (1680)	5160 (1510)	4610 (1350)				
TEHA025M6 Compressor Model CS14K6E	30 (-1.1)		26400 (7740)	25000 (7330)	23500 (6890)	22100 (6480)	20700 (6070)	19200 (5630)	17800 (5220)			
	25 (-3.9)		24200 (7090)	22900 (6710)	21600 (6330)	20300 (5950)	19000 (5570)	17700 (5190)	16300 (4780)			
	20 (-6.7)		22100 (6480)	20900 (6130)	19700 (5770)	18500 (5420)	17300 (5070)	16100 (4720)	14900 (4370)			
	15 (-9.4)		20000 (5860)	18900 (5540)	17800 (5220)	16700 (4890)	15600 (4570)	14500 (4250)	13400 (3930)			
	10 (-12.2)		17900 (5250)	16900 (4950)	15900 (4660)	14900 (4370)	13900 (4070)	13000 (3810)	12000 (3520)			
	5 (-15.0)		15900 (4660)	15000 (4400)	14100 (4130)	13200 (3870)	12300 (3600)	11400 (3340)	10500 (3080)			
	0 (-17.8)		14000 (4100)	13200 (3870)	12400 (3630)	11600 (3400)	10800 (3170)	9950 (2920)	9160 (2680)			
-5 (-20.6)		11500 (3370)	10800 (3170)	10200 (2990)	9480 (2780)	8800 (2580)	8120 (2380)	7450 (2180)				
-10 (-23.3)		9880 (2900)	9300 (2730)	8680 (2540)	8070 (2370)	7470 (2190)	6860 (2010)	6260 (1830)				
TEHA029M6 Compressor Model CS18K6E	30 (-1.1)		32200 (9440)	30400 (8910)	28600 (8380)	26800 (7850)	24900 (7300)	23100 (6770)	21300 (6240)			
	25 (-3.9)		29800 (8730)	28100 (8240)	26300 (7710)	24600 (7210)	23000 (6740)	21300 (6240)	19600 (5740)			
	20 (-6.7)		27200 (7970)	25600 (7500)	24100 (7060)	22500 (6590)	20900 (6130)	19400 (5690)	17800 (5220)			
	15 (-9.4)		24700 (7240)	23200 (6800)	21700 (6360)	20300 (5950)	18800 (5510)	17400 (5100)	16000 (4690)			
	10 (-12.2)		22100 (6480)	20800 (6100)	19400 (5690)	18100 (5300)	16800 (4920)	15500 (4540)	14200 (4160)			
	5 (-15.0)		19600 (5740)	18400 (5390)	17100 (5010)	15900 (4660)	14700 (4310)	13500 (3960)	12400 (3630)			
	0 (-17.8)		17200 (5040)	16100 (4720)	14900 (4370)	13800 (4040)	12700 (3720)	11700 (3430)	10600 (3110)			
-5 (-20.6)		14100 (4130)	13100 (3840)	12200 (3580)	11200 (3280)	10400 (3050)	9400 (2750)	8540 (2500)				
-10 (-23.3)		12000 (3520)	11100 (3250)	10300 (3020)	9460 (2770)	8650 (2540)	7860 (2300)	7100 (2080)				
TEHA030M6 Compressor Model CS18K6E	30 (-1.1)		36200 (10610)	34300 (10050)	32300 (9470)	30300 (8880)	28300 (8290)	26300 (7710)	24400 (7150)			
	25 (-3.9)		33200 (9730)	31400 (9200)	29600 (8670)	27700 (8120)	25900 (7590)	24000 (7030)	22200 (6510)			
	20 (-6.7)		30200 (8850)	28500 (8350)	26800 (7850)	25100 (7360)	23400 (6860)	21700 (6360)	20000 (5860)			
	15 (-9.4)		27200 (7970)	25600 (7500)	24100 (7060)	22500 (6590)	20900 (6130)	19400 (5690)	17800 (5220)			
	10 (-12.2)		24200 (7090)	22800 (6680)	21400 (6270)	19900 (5830)	18500 (5420)	17100 (5010)	15700 (4600)			
	5 (-15.0)		21300 (6240)	20000 (5860)	18700 (5480)	17400 (5100)	16100 (4720)	14800 (4340)	13600 (3990)			
	0 (-17.8)		18500 (5420)	17400 (5100)	16200 (4750)	15000 (4400)	13800 (4040)	12700 (3720)	11600 (3400)			
-5 (-20.6)		15100 (4430)	14200 (4160)	13100 (3840)	12200 (3580)	11100 (3250)	10200 (2990)	9220 (2700)				
-10 (-23.3)		12800 (3750)	11900 (3490)	11000 (3220)	10200 (2990)	9360 (2740)	8420 (2470)	7610 (2230)				
TEHA035M6 Compressor Model CS20K6E	30 (-1.1)		41700 (12220)	39300 (11520)	36900 (10810)	34600 (10140)	32200 (9440)	30000 (8790)	27800 (8150)			
	25 (-3.9)		37400 (10960)	35200 (10320)	33000 (9670)	30800 (9030)	28700 (8410)	26600 (7800)	24600 (7210)			
	20 (-6.7)		33400 (9790)	31400 (9200)	29400 (8620)	27400 (8030)	25500 (7470)	23600 (6920)	21700 (6360)			
	15 (-9.4)		29800 (8730)	27900 (8180)	26100 (7650)	24300 (7120)	22500 (6590)	20800 (6100)	19100 (5600)			
	10 (-12.2)		26500 (7770)	24800 (7270)	23100 (6770)	21500 (6300)	19900 (5830)	18300 (5360)	16700 (4890)			
	5 (-15.0)		23400 (6860)	21900 (6420)	20400 (5980)	18900 (5540)	17400 (5100)	16000 (4690)	14600 (4280)			
	0 (-17.8)		20600 (6040)	19300 (5660)	17900 (5250)	16500 (4840)	15200 (4450)	13900 (4070)	12600 (3690)			
-5 (-20.6)		17200 (5040)	16000 (4690)	14800 (4340)	13700 (4020)	12400 (3630)	11300 (3310)	10300 (3020)				
-10 (-23.3)		14900 (4370)	13800 (4040)	12700 (3720)	11700 (3430)	10600 (3110)	9600 (2810)	8540 (2500)				

--- Outside Operating Range † Max 40°F RGT * Not suitable for use with R-507

ELECTRICAL DATA COPELAND MODELS

MODEL TEH	COMPRESSOR MODEL NO.	POWER SUPPLY	COMPRESSOR		CONDENSER FAN MOTOR			UNIT		
			RLA	LRA	QTY	WATTS	FLA	MCA	MOP	
TEHA015H7- *	S2C	CR18K6E-PFV	208-230/1/60	9.4	49.0	1	240	1.1	12.9	20
	T3C	CR18K6E-TF5	208-230/3/60	5.4	49.0	1	240	1.1	7.9	15
TEHA020H7- *	S2C	CR24K6E-PFV	208-230/1/60	11.2	61.0	1	240	1.1	15.1	25
	T3C	CR24K6E-TF5	208-230/3/60	6.9	55.0	1	240	1.1	9.7	15
	T4C	CR24K6E-TFD	460/3/60	3.6	28.0	1	240	0.6	5.1	15
TEHA025H7- *	S2C	CR32K6E-PFV	208-230/1/60	14.4	82.0	1	240	1.1	19.1	30
	T3C	CR32K6E-TF5	208-230/3/60	9.0	72.0	1	240	1.1	12.4	20
	T4C	CR32K6E-TFD	460/3/60	4.6	33.0	1	240	0.6	6.3	15
TEHA029H7- *	S2C	CR38K6E-PFV	208-230/1/60	17.1	105.0	1	240	1.1	22.5	35
	T3C	CR38K6E-TF5	208-230/3/60	10.7	85.0	1	240	1.1	14.5	25
	T4C	CR38K6E-TFD	460/3/60	5.3	42.0	1	240	0.6	7.2	15
TEHA030H7- *	S2C	CR38K6E-PFV	208-230/1/60	17.1	105.0	1	400	2.1	23.5	40
	T3C	CR38K6E-TF5	208-230/3/60	10.7	85.0	1	400	2.1	15.5	25
	T4C	CR38K6E-TFD	460/3/60	5.3	42.0	1	400	1.1	7.7	15
TEHA035H7- *	S2C	CR42K6E-PFV	208-230/1/60	18.3	102.0	1	400	2.1	25.0	40
	T3C	CR42K6E-TF5	208-230/3/60	12.6	91.0	1	400	2.1	17.9	30
	T4C	CR42K6E-TFD	460/3/60	5.7	42.0	1	400	1.1	8.2	15
	T5C	CR42K6E-TFE	575/3/60	4.7	39.0	1	400	0.9	6.7	15
	S2C	CR53KQE-PFV	208-230/1/60	26.0	140.0	1	400	2.1	34.6	60
TEHA040H7- *	T3C	CR53KQE-TF5	208-230/3/60	16.3	107.0	1	400	2.1	22.5	35
	T4C	CR53KQE-TFD	460/3/60	8.1	55.0	1	400	1.1	11.3	15
	S2C	CRNQ-050E-PFV	208-230/1/60	30.8	142.0	1	400	2.1	40.6	70
TEHA050H7- *	T3C	CRNQ-050E-TF5	208-230/3/60	19.2	130.0	1	400	2.1	26.1	45
	T4C	CRNQ-050E-TFD	460/3/60	8.7	65.0	1	400	1.1	11.9	20
	T5C	CRNQ-050E-TFE	575/3/60	7.1	52.0	1	400	0.9	9.7	15
TEHA006M8- *	S1C	RST45C1E-CAA	115/1/60	9.4	54.5	1	130	1.2	13.0	20
	S2C	RST45C1E-CAV	208-230/1/60	4.6	26.5	1	130	0.5	6.3	15
TEHA008M8- *	S1C	RST55C1E-CAA	115/1/60	13.5	70.0	1	130	1.2	18.1	30
	S2C	RST55C1E-CAV	208-230/1/60	6.1	33.7	1	130	0.5	8.1	15
TEHA009M8- *	S2C	RST64C1E-CAV	208-230/1/60	8.0	43.0	1	130	0.5	10.5	15
TEHA010M8- *	S2C	RST70C1E-PFV	208-230/1/60	6.9	46.0	1	130	0.5	9.1	15
	T3C	RST70C1E-TA5	208-230/3/60	4.9	36.0	1	130	0.5	6.6	15
TEHA011M8- *	S2C	RST80C1E-PFV	208-230/1/60	8.3	46.0	1	130	0.5	10.9	15
	T3C	RST80C1E-TA5	208-230/3/60	5.1	36.0	1	130	0.5	6.9	15
TEHA013M8- *	S2C	RST97C1E-PFV	208-230/1/60	9.0	51.0	1	240	1.1	12.4	20
	T3C	RST97C1E-TA5	208-230/3/60	5.4	36.0	1	240	1.1	7.9	15
TEHA015M6- *	S2C	CS10K6E-PFV	208-230/1/60	9.8	56.0	1	240	1.1	13.4	20
	T3C	CS10K6E-TF5	208-230/3/60	6.7	51.0	1	240	1.1	9.5	15
	T4C	CS10K6E-TFD	460/3/60	3.2	25.0	1	240	0.6	4.6	15
TEHA020M6- *	S2C	CS12K6E-PFV	208-230/1/60	9.8	56.0	1	240	1.1	13.4	20
	T3C	CS12K6E-TF5	208-230/3/60	6.7	51.0	1	240	1.1	9.5	15
TEHA025M6- *	S2C	CS14K6E-PFV	208-230/1/60	11.2	61.0	1	240	1.1	15.1	25
	T3C	CS14K6E-TF5	208-230/3/60	8.2	55.0	1	240	1.1	11.4	15
	T4C	CS14K6E-TFD	460/3/60	4.2	28.0	1	240	0.6	5.9	15
TEHA029M6- *	S2C	CS18K6E-PFV	208-230/1/60	14.4	82.0	1	240	1.1	19.0	30
	T3C	CS18K6E-TF5	208-230/3/60	7.9	65.5	1	240	1.1	11.0	15
	T4C	CS18K6E-TFD	460/3/60	4.2	33.0	1	240	0.6	5.9	15
TEHA030M6- *	S2C	CS18K6E-PFV	208-230/1/60	14.4	82.0	1	400	2.1	20.0	30
	T3C	CS18K6E-TF5	208-230/3/60	7.9	65.5	1	400	2.1	12.0	15
	T4C	CS18K6E-TFD	460/3/60	4.2	33.0	1	400	1.1	6.4	15
TEHA035M6- *	S2C	CS20K6E-PFV	208-230/1/60	16.7	96.0	1	400	2.1	22.9	35
	T3C	CS20K6E-TF5	208-230/3/60	10.2	75.0	1	400	2.1	14.9	25
	T4C	CS20K6E-TFD	460/3/60	4.6	40.0	1	400	1.1	6.8	15
TEHA006L6- *	S1C	RFT22C1E-CAA	115/1/60	7.1	54.5	1	130	1.2	10.1	15
	S2C	RFT22C1E-CAV	208-230/1/60	4.7	29.0	1	130	0.5	6.4	15
TEHA008L6- *	S1C	RFT26C1E-CAA	115/1/60	9.7	66.0	1	130	1.2	13.3	20
	S2C	RFT26C1E-CAV	208-230/1/60	5.8	35.5	1	130	0.5	7.8	15
TEHA010L6- *	S2C	CF04K6E-PFV	208-230/1/60	9.9	59.2	1	130	0.5	12.9	20
	T3C	CF04K6E-TF5	208-230/3/60	6.1	52.0	1	130	0.5	8.1	15
TEHA015L6- *	S2C	CF06K6E-PFV	208-230/1/60	10.3	59.2	1	130	0.5	13.3	20
	T3C	CF06K6E-TF5	208-230/3/60	6.3	52.0	1	130	0.5	8.4	15
TEHA020L6- *	S2C	CF06K6E-PFV	208-230/1/60	10.3	59.2	1	130	0.5	13.3	20
	T3C	CF06K6E-TF5	208-230/3/60	6.3	52.0	1	130	0.5	8.4	15
TEHA025L6- *	S2C	CF09K6E-PFV	208-230/1/60	15.0	87.0	1	240	1.1	19.9	30
	T3C	CF09K6E-TF5	208-230/3/60	9.2	72.2	1	240	1.1	12.6	20
	T4C	CF09K6E-TFD	460/3/60	4.9	35.8	1	240	0.6	6.8	15
TEHA030L6- *	S2C	CF12K6E-PFV	208-230/1/60	18.4	105.0	1	240	1.1	24.1	40
	T3C	CF12K6E-TF5	208-230/3/60	11.0	85.0	1	240	1.1	14.9	25
	T4C	CF12K6E-TFD	460/3/60	5.9	42.0	1	240	0.6	8.0	15

* I = Indoor, H = Outdoor. Above listed RLA value is based on UL rating method and may differ from published compressor RLA data.

MODEL TEH	COMPRESSOR MODEL NO.	POWER SUPPLY	COMPRESSOR		ECM CONDENSER FAN			UNIT		
			RLA	LRA	QTY	WATTS	FLA	MCA	MOP	
TEHA015H7-*	S2C	CR18K6E-PFV	208-230/1/60	9.4	49.0	1	175	2.0	13.8	20
	T3C	CR18K6E-TF5	208-230/3/60	5.4	49.0	1	175	2.0	8.8	15
TEHA020H7-*	S2C	CR24K6E-PFV	208-230/1/60	11.2	61.0	1	175	2.0	16.0	25
	T3C	CR24K6E-TF5	208-230/3/60	6.9	55.0	1	175	2.0	10.6	15
TEHA025H7-*	S2C	CR32K6E-PFV	208-230/1/60	14.4	82.0	1	175	2.0	20.0	30
	T3C	CR32K6E-TF5	208-230/3/60	9.0	72.0	1	175	2.0	13.3	20
TEHA029H7-*	S2C	CR38K6E-PFV	208-230/1/60	17.1	105.0	1	175	2.0	23.4	40
	T3C	CR38K6E-TF5	208-230/3/60	10.7	85.0	1	175	2.0	15.4	25
TEHA030H7-*	S2C	CR38K6E-PFV	208-230/1/60	17.1	105.0	1	315	3.5	24.9	40
	T3C	CR38K6E-TF5	208-230/3/60	10.7	85.0	1	315	3.5	16.9	25
TEHA035H7-*	S2C	CR42K6E-PFV	208-230/1/60	18.3	102.0	1	315	3.5	26.4	40
	T3C	CR42K6E-TF5	208-230/3/60	12.6	91.0	1	315	3.5	19.3	30
TEHA040H7-*	S2C	CR53KQE-PFV	208-230/1/60	26.0	140.0	1	315	3.5	36.0	60
	T3C	CR53KQE-TF5	208-230/3/60	16.3	107.0	1	315	3.5	23.9	40
TEHA050H7-*	S2C	CRNQ-050E-PFV	208-230/1/60	30.8	142.0	1	315	3.5	42.0	70
	T3C	CRNQ-050E-TF5	208-230/3/60	19.2	130.0	1	315	3.5	27.5	45
TEHA006M8-*	S2C	RST45C1E-CAV	208-230/1/60	4.6	26.5	1	100	1.0	6.8	15
TEHA008M8-*	S2C	RST55C1E-CAV	208-230/1/60	6.1	33.7	1	100	1.0	8.6	15
TEHA009M8-*	S2C	RST64C1E-CAV	208-230/1/60	8.1	43.0	1	100	1.0	11.1	15
TEHA010M8-*	S2C	RST70C1E-PFV	208-230/1/60	6.9	46.0	1	100	1.0	9.6	15
	T3C	RST70C1E-TFC	208-230/3/60	4.9	36.0	1	100	1.0	7.1	15
TEHA011M8-*	S2C	RST80C1E-PFV	208-230/1/60	8.3	46.0	1	100	1.0	11.4	15
	T3C	RST80C1E-TA5	208-230/3/60	5.1	36.0	1	100	1.0	7.4	15
TEHA013M8-*	S2C	RST97C1E-PFV	208-230/1/60	9.0	51.0	1	175	2.0	13.3	20
	T3C	RST97C1E-TA5	208-230/3/60	5.4	36.0	1	175	2.0	8.8	15
TEHA015M6-*	S2C	CS10K6E-PFV	208-230/1/60	9.8	56.0	1	175	2.0	14.3	20
	T3C	CS10K6E-TF5	208-230/3/60	6.7	51.0	1	175	2.0	10.4	15
TEHA020M6-*	S2C	CS12K6E-PFV	208-230/1/60	9.8	56.0	1	175	2.0	14.3	20
	T3C	CS12K6E-TF5	208-230/3/60	6.7	51.0	1	175	2.0	10.4	15
TEHA025M6-*	S2C	CS14K6E-PFV	208-230/1/60	11.2	61.0	1	175	2.0	16.0	25
	T3C	CS14K6E-TF5	208-230/3/60	8.2	55.0	1	175	2.0	12.3	20
TEHA029M6-*	S2C	CS18K6E-PFV	208-230/1/60	14.4	82.0	1	175	2.0	19.9	30
	T3C	CS18K6E-TF5	208-230/3/60	9.4	65.5	1	175	2.0	13.8	20
TEHA030M6-*	S2C	CS18K6E-PFV	208-230/1/60	14.4	82.0	1	315	3.5	21.4	35
	T3C	CS18K6E-TF5	208-230/3/60	9.4	65.5	1	315	3.5	15.3	20
TEHA035M6-*	S2C	CS20K6E-PFV	208-230/1/60	16.7	96.0	1	315	3.5	24.3	40
	T3C	CS20K6E-TF5	208-230/3/60	10.2	75.0	1	315	3.5	16.3	25
TEHA006L6-*	S2C	RFT22C1E-CAV	208-230/1/60	4.7	29.0	1	100	1.0	6.9	15
TEHA008L6-*	S2C	RFT26C1E-CAV	208-230/1/60	5.8	35.5	1	100	1.0	8.3	15
TEHA010L6-*	S2C	CF04K6E-PFV	208-230/1/60	8.6	59.2	1	100	1.0	11.8	20
	T3C	CF04K6E-TF5	208-230/3/60	5.7	52.0	1	100	1.0	8.1	15
TEHA015L6-*	S2C	CF06K6E-PFV	208-230/1/60	10.3	59.2	1	100	1.0	13.8	20
	T3C	CF06K6E-TF5	208-230/3/60	6.3	52.0	1	100	1.0	8.9	15
TEHA020L6-*	S2C	CF06K6E-PFV	208-230/1/60	10.3	59.2	1	100	1.0	13.8	20
	T3C	CF06K6E-TF5	208-230/3/60	6.3	52.0	1	100	1.0	8.9	15
TEHA025L6-*	S2C	CF09K6E-PFV	208-230/1/60	15.0	87.0	1	175	2.0	20.8	35
	T3C	CF09K6E-TF5	208-230/3/60	9.2	72.2	1	175	2.0	13.5	20
TEHA030L6-*	S2C	CF12K6E-PFV	208-230/1/60	18.4	105.0	1	175	2.0	25.0	40
	T3C	CF12K6E-TF5	208-230/3/60	11.0	85.0	1	175	2.0	15.8	25

* I = Indoor, H = Outdoor. Above listed RLA value is based on UL rating method and may differ from published compressor RLA data.

† Applies to units with variable speed EC motors or SmartSpeed (1/2 - 5 HP only). Contact factory for details.

DRAWING #1

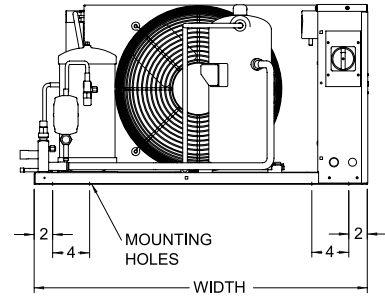
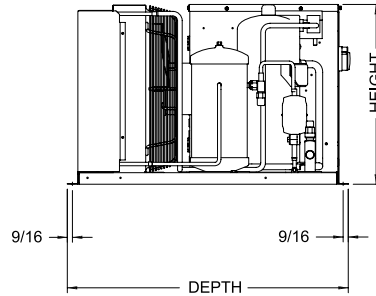
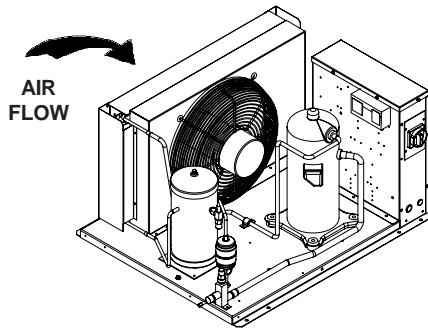

INDOOR DIMENSIONS

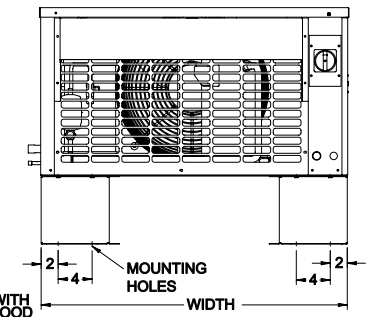
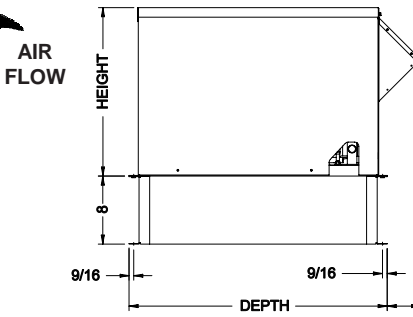
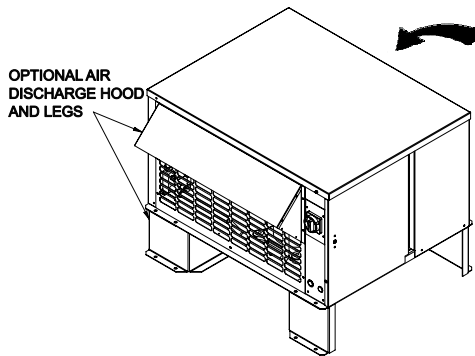

OUTDOOR DIMENSIONS

NOTE: Discharge hood, legs and wind guard are optional components

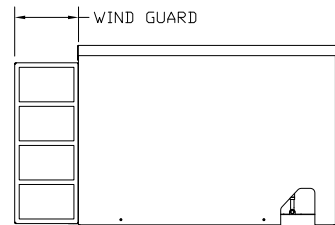
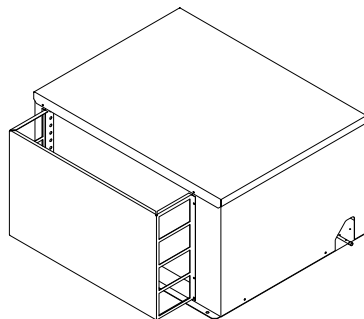

**REFER TO PAGE 16 FOR
DIMENSIONAL DATA FOR SPECIFIC MODELS**

**DIMENSIONAL DATA
(Large Chassis Models)**

DRAWING #2

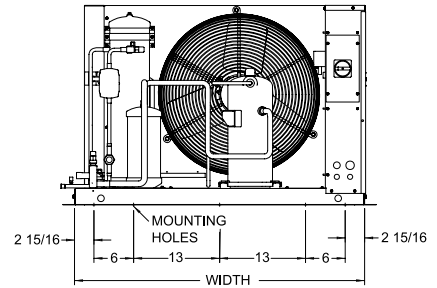
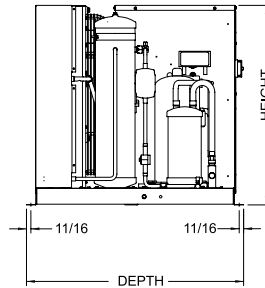
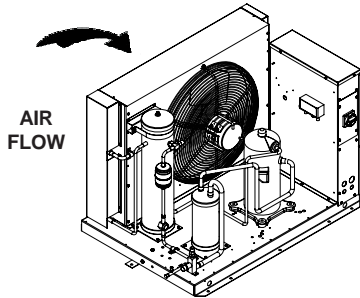

INDOOR DIMENSIONS

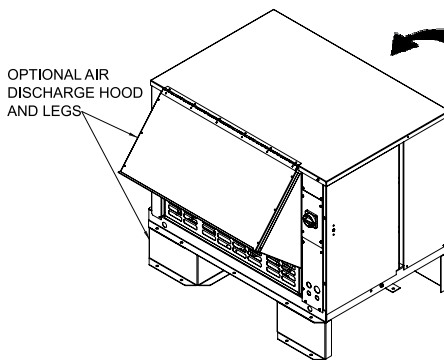

AIR FLOW

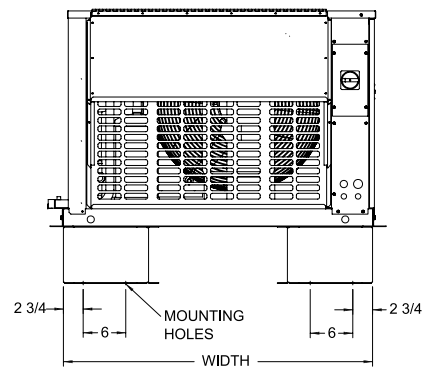
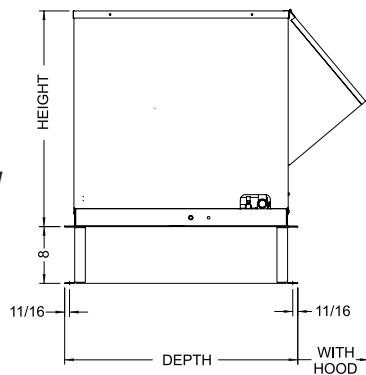

OUTDOOR DIMENSIONS

NOTE: Discharge hood, legs and wind guard are optional components

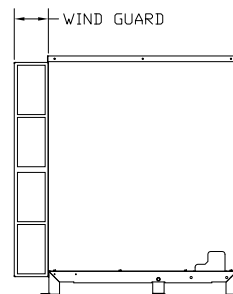
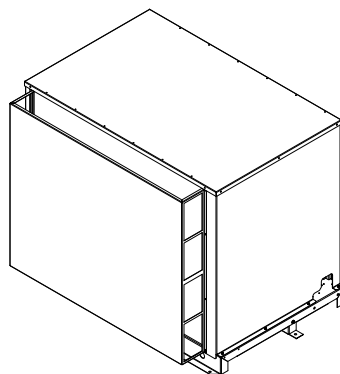

**REFER TO PAGE 16 FOR
DIMENSIONAL DATA FOR SPECIFIC MODELS**

DIMENSIONAL DATA
COPELAND MODELS

MODEL TEH	CHASSIS	DRAWING # (see table below)	OUTDOOR MODELS										INDOOR MODELS					
			WIDTH		DEPTH						HEIGHT		WIDTH		DEPTH		HEIGHT	
					Base	With Hood, add:		Wind Guard, add:										
Inches	mm	Inches	mm	Inches	mm	Inches	mm	Inches	mm	Inches	mm	Inches	mm	Inches	mm	Inches	mm	
TEHA015H7	B	1	36 3/8	924	30 3/8	772	34 3/8	873	19 7/8	505	19 7/8	505	36 1/8	918	30 3/8	772	19 1/2	495
TEHA020H7		1	36 3/8	924	30 3/8	772	34 3/8	873	19 7/8	505	19 7/8	505	36 1/8	918	30 3/8	772	19 1/2	495
TEHA025H7		1	36 3/8	924	30 3/8	772	34 3/8	873	19 7/8	505	19 7/8	505	36 1/8	918	30 3/8	772	19 1/2	495
TEHA029H7		1	36 3/8	924	30 3/8	772	34 3/8	873	19 7/8	505	19 7/8	505	36 1/8	918	30 3/8	772	19 1/2	495
TEHA030H7	C	2	43 7/8	1114	32 7/8	835	43	1092	30 3/8	772	30 3/8	772	43 7/8	1114	32 7/8	835	30 3/16	767
TEHA035H7		2	43 7/8	1114	32 7/8	835	43	1092	30 3/8	772	30 3/8	772	43 7/8	1114	32 7/8	835	30 3/16	767
TEHA040H7		2	43 7/8	1114	32 7/8	835	43	1092	30 3/8	772	30 3/8	772	43 7/8	1114	32 7/8	835	30 3/16	767
TEHA050H7		2	43 7/8	1114	32 7/8	835	43	1092	30 3/8	772	30 3/8	772	43 7/8	1114	32 7/8	835	30 3/16	767
TEHA006M8	A	1	24 7/8	632	30 3/8	772	34 3/8	873	19 3/8	492	16 7/8	429	24 5/8	625	30 3/8	772	19	483
TEHA008M8		1	24 7/8	632	30 3/8	772	34 3/8	873	19 3/8	492	16 7/8	429	24 5/8	625	30 3/8	772	19	483
TEHA009M8		1	24 7/8	632	30 3/8	772	34 3/8	873	19 3/8	492	16 7/8	429	24 5/8	625	30 3/8	772	19	483
TEHA010M8		1	24 7/8	632	30 3/8	772	34 3/8	873	19 3/8	492	16 7/8	429	24 5/8	625	30 3/8	772	19	483
TEHA011M8		1	24 7/8	632	30 3/8	772	34 3/8	873	19 3/8	429	19 7/8	505	24 5/8	625	30 3/8	772	19	419
TEHA013M8	B	1	36 3/8	924	30 3/8	772	34 3/8	873	19 7/8	505	19 7/8	505	36 1/8	918	30 3/8	772	19 1/2	495
TEHA015M6	B	1	36 3/8	924	30 3/8	772	34 3/8	873	19 7/8	505	19 7/8	505	36 1/8	918	30 3/8	772	19 1/2	495
TEHA020M6		1	36 3/8	924	30 3/8	772	34 3/8	873	19 7/8	505	19 7/8	505	36 1/8	918	30 3/8	772	19 1/2	495
TEHA025M6		1	36 3/8	924	30 3/8	772	34 3/8	873	19 7/8	505	19 7/8	505	36 1/8	918	30 3/8	772	19 1/2	495
TEHA029M6		1	36 3/8	924	30 3/8	772	34 3/8	873	19 7/8	505	19 7/8	505	36 1/8	918	30 3/8	772	19 1/2	495
TEHA030M6	C	2	43 7/8	1114	32 7/8	835	43	1092	30 3/8	772	30 3/8	772	43 7/8	1114	32 7/8	835	30 3/16	767
TEHA035M6		2	43 7/8	1114	32 7/8	835	43	1092	30 3/8	772	30 3/8	772	43 7/8	1114	32 7/8	835	30 3/16	767
TEHA006L6	A	1	24 7/8	632	30 3/8	772	34 3/8	873	19 3/8	492	16 7/8	429	24 5/8	625	30 3/8	772	19	483
TEHA008L6		1	24 7/8	632	30 3/8	772	34 3/8	873	19 3/8	492	16 7/8	429	24 5/8	625	30 3/8	772	19	483
TEHA010L6		1	24 7/8	632	30 3/8	772	34 3/8	873	19 3/8	492	16 7/8	429	24 5/8	625	30 3/8	772	19	483
TEHA015L6		1	24 7/8	632	30 3/8	772	34 3/8	873	19 3/8	492	16 7/8	429	24 5/8	625	30 3/8	772	19	483
TEHA020L6		1	24 7/8	632	30 3/8	772	34 3/8	873	19 3/8	492	16 7/8	429	24 5/8	625	30 3/8	772	19	483
TEHA025L6	B	1	36 3/8	924	30 3/8	772	34 3/8	873	19 7/8	505	19 7/8	505	36 1/8	918	30 3/8	772	19 1/2	495
TEHA030L6		1	36 3/8	924	30 3/8	772	34 3/8	873	19 7/8	505	19 7/8	505	36 1/8	918	30 3/8	772	19 1/2	495

DRAWING #	PAGE #
1	14
2	15

MODEL TEH	UNIT CONNECTIONS				R404A		APPROX. SHIPPING WEIGHT			
	SUCTION (OD)		LIQUID (OD)		RECEIVER CAPACITY 90% FULL *		OUTDOOR MODELS		INDOOR MODELS	
	Inches	mm	Inches	mm	Lbs.	Kgs	Lbs.	Kgs	Lbs.	Kgs
TEHA015H7	5/8	16	3/8	10	13	5.90	277	126	252	114
TEHA020H7	5/8	16	3/8	10	13	5.90	282	128	257	117
TEHA025H7	7/8	22	3/8	10	16	7.26	292	132	267	121
TEHA029H7	7/8	22	1/2	13	16	7.26	298	135	273	124
TEHA030H7	7/8	22	1/2	13	24	10.89	394	179	349	158
TEHA035H7	7/8	22	1/2	13	24	10.89	394	179	349	158
TEHA040H7	1 1/8	29	1/2	13	24	10.89	405	184	360	163
TEHA050H7	1 1/8	29	1/2	13	24	10.89	415	188	370	168
TEHA006M8	5/8	16	3/8	10	5.4	2.45	149	68	127	58
TEHA008M8	5/8	16	3/8	10	5.4	2.45	149	68	127	58
TEHA009M8	5/8	16	3/8	10	5.4	2.45	152	69	130	59
TEHA010M8	5/8	16	3/8	10	5.4	2.45	167	76	145	66
TEHA011M8	5/8	16	3/8	10	5.4	2.45	167	76	145	66
TEHA013M8	5/8	16	3/8	10	11.3	5.13	279	127	257	117
TEHA015M6	5/8	16	3/8	10	11.3	5.13	279	127	257	117
TEHA020M6	5/8	16	3/8	10	11.3	5.13	282	128	255	116
TEHA025M6	7/8	22	1/2	13	14.4	6.53	286	130	259	117
TEHA029M6	7/8	22	1/2	13	14.4	6.53	292	132	265	120
TEHA030M6	7/8	22	1/2	13	21.5	9.75	388	176	343	156
TEHA035M6	7/8	22	1/2	13	21.5	9.75	389	176	344	156
TEHA006L6	1/2	13	3/8	10	5.4	2.45	141	64	119	54
TEHA008L6	1/2	13	3/8	10	5.4	2.45	141	64	119	54
TEHA010L6	5/8	16	3/8	10	5.4	2.45	187	85	165	75
TEHA015L6	7/8	22	3/8	10	5.4	2.45	190	86	168	76
TEHA020L6	7/8	22	3/8	10	5.4	2.45	194	88	172	78
TEHA025L6	7/8	22	3/8	10	14.4	6.53	281	127	254	115
TEHA030L6	7/8	22	1/2	13	14.4	6.53	292	132	265	120

*** NOTE ON ALTERNATE REFRIGERANTS:**

* PUBLISHED RECEIVER CAPACITY IS BASED ON **R404A** ON MODELS USING "8" AS REFRIGERANT CODE.
FOR ALERNATE REFRIGERANTS, MULTIPLY **R404A** VALUE BY THE APPROPRIATE VALUE BELOW:

R407A	R407C	R448A	R507	R22
1.10	1.10	1.05	1.00	1.15

- For R449A, use R448A data.

**ANNUAL WALK-IN ENERGY
FACTOR (AWEF) RATINGS
FOR HIGH/MEDIUM TEMP. APPLICATIONS**

BASE UNIT MODEL TEH	AWEF	
	OUTDOOR MODELS	INDOOR MODELS
TEHA015H7	6.94	5.59
TEHA020H7	7.24	5.80
TEHA025H7	7.45	5.98
TEHA029H7	7.47	5.82
TEHA030H7	7.81	6.27
TEHA035H7	7.91	6.46
TEHA040H7	7.36	6.03
TEHA050H7	7.15	5.84

BASE UNIT MODEL TEH	AWEF	
	OUTDOOR MODELS	INDOOR MODELS
TEHA006M8	6.05	4.90
TEHA008M8	6.17	4.77
TEHA009M8	5.65	4.48
TEHA010M8	6.68	5.47
TEHA011M8	6.67	5.40
TEHA013M8	6.47	5.38
TEHA015M6	7.67	5.71
TEHA020M6	7.79	5.72
TEHA025M6	7.82	5.83
TEHA029M6	8.07	5.86
TEHA030M6	8.24	6.25
TEHA035M6	8.17	6.15

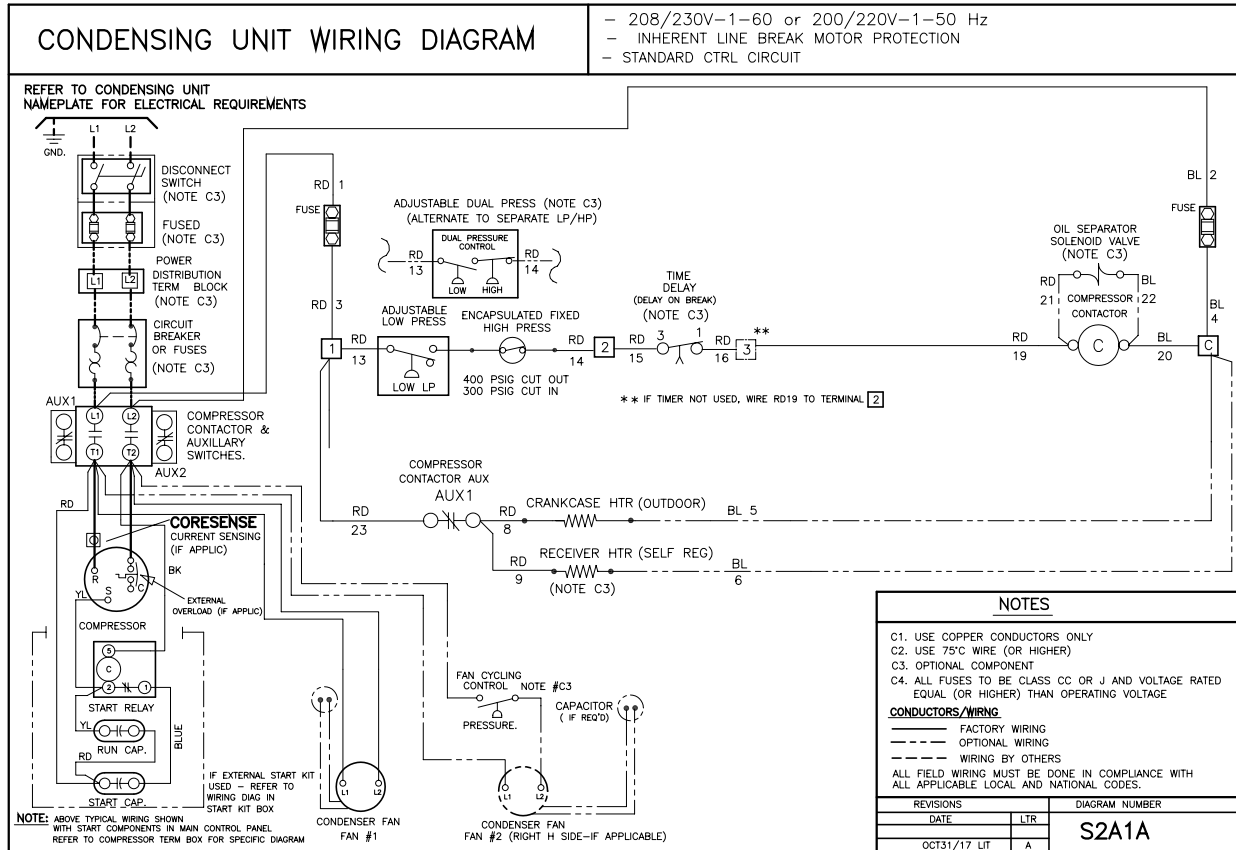

TYPICAL EVAPORATOR WIRING: FOR SINGLE AIR DEFROST EVAPORATOR— SINGLE POINT

FOR USE WITH: 208/230-1-60, 200/220-1-50 OR 208/230-3-60, 200/220-3-50 CONDENSING UNITS WITH OR WITHOUT DEFROST TIME CLOCK AND FOR TOTAL EVAP FAN AMPS NOT EXCEEDING 12A

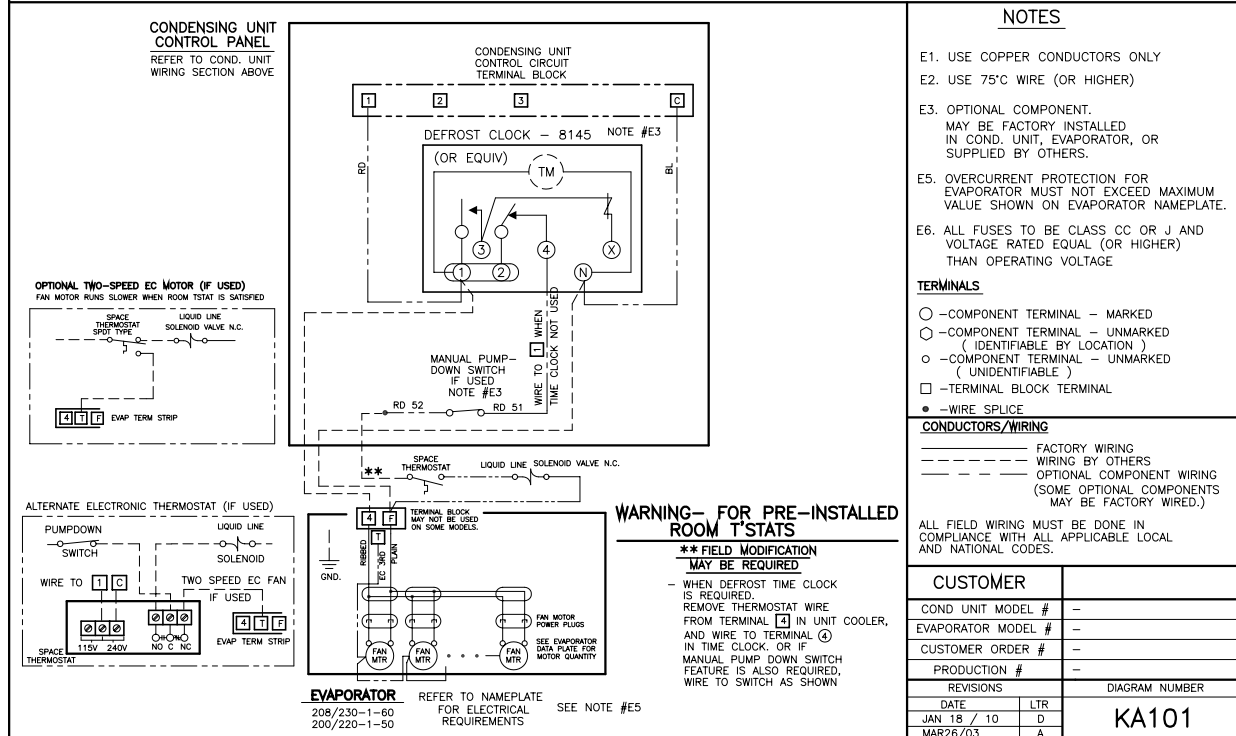

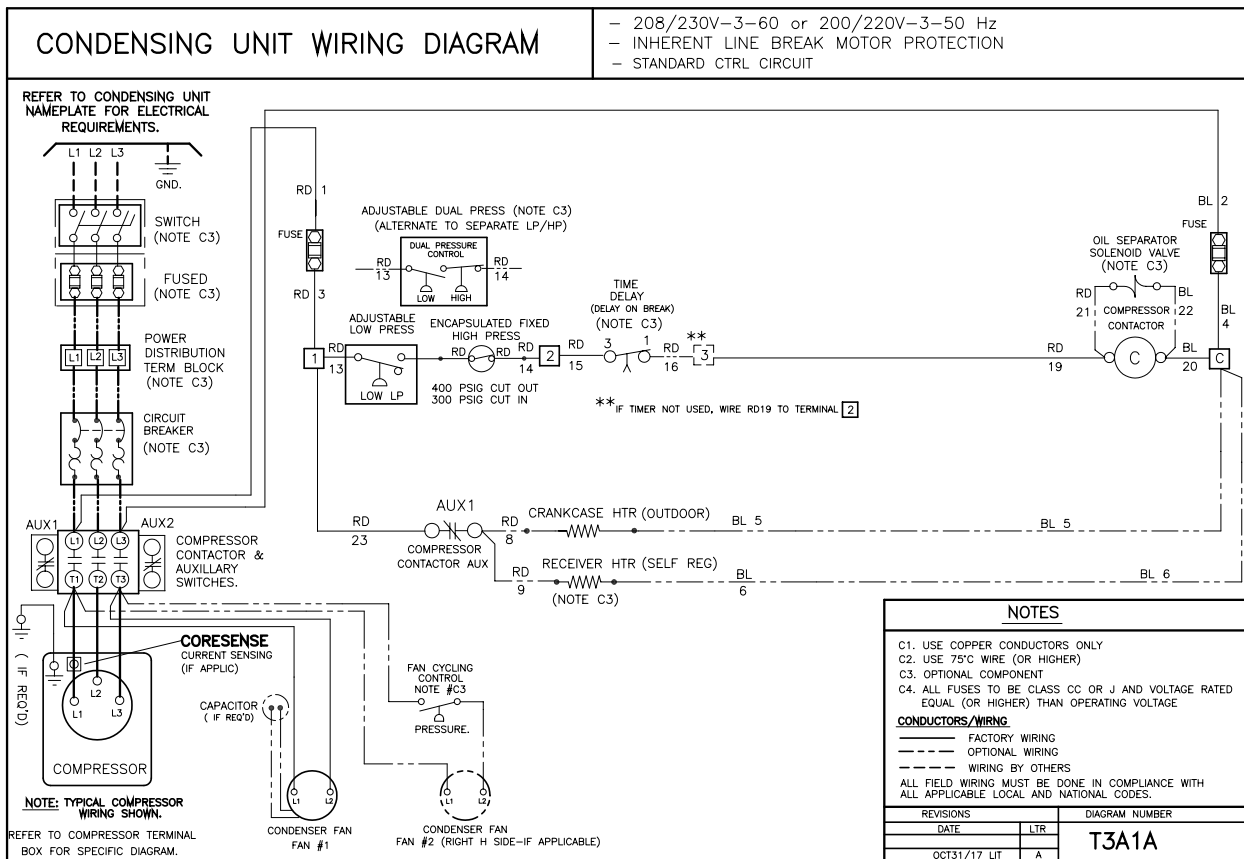

TYPICAL EVAPORATOR WIRING: FOR SINGLE LOW PROFILE ELECT 1 PHASE DEFROST EVAPORATOR—SINGLE POINT

FOR USE WITH: 230V SINGLE OR THREE PHASE CONDENSING UNITS WITH DEFROST TIME CLOCK, AND DEFROST HEATER CONTACTOR

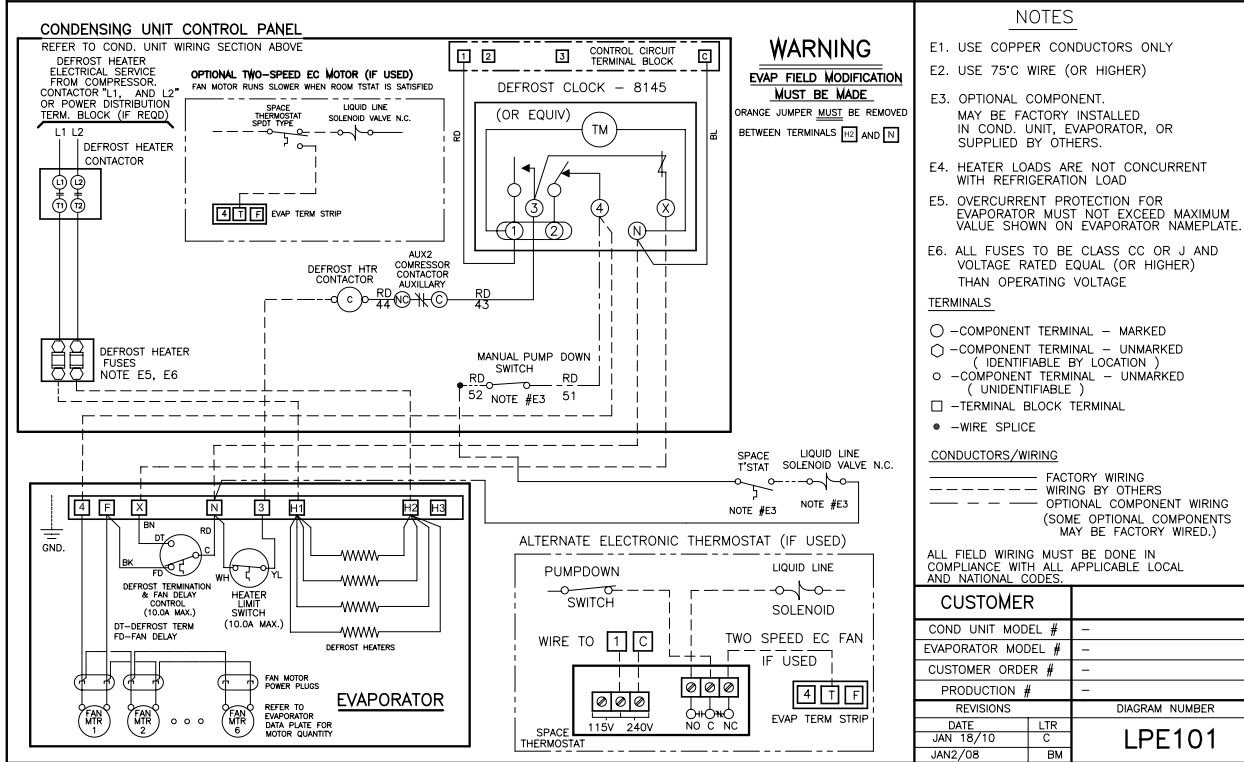

460/3/60, 575/3/60

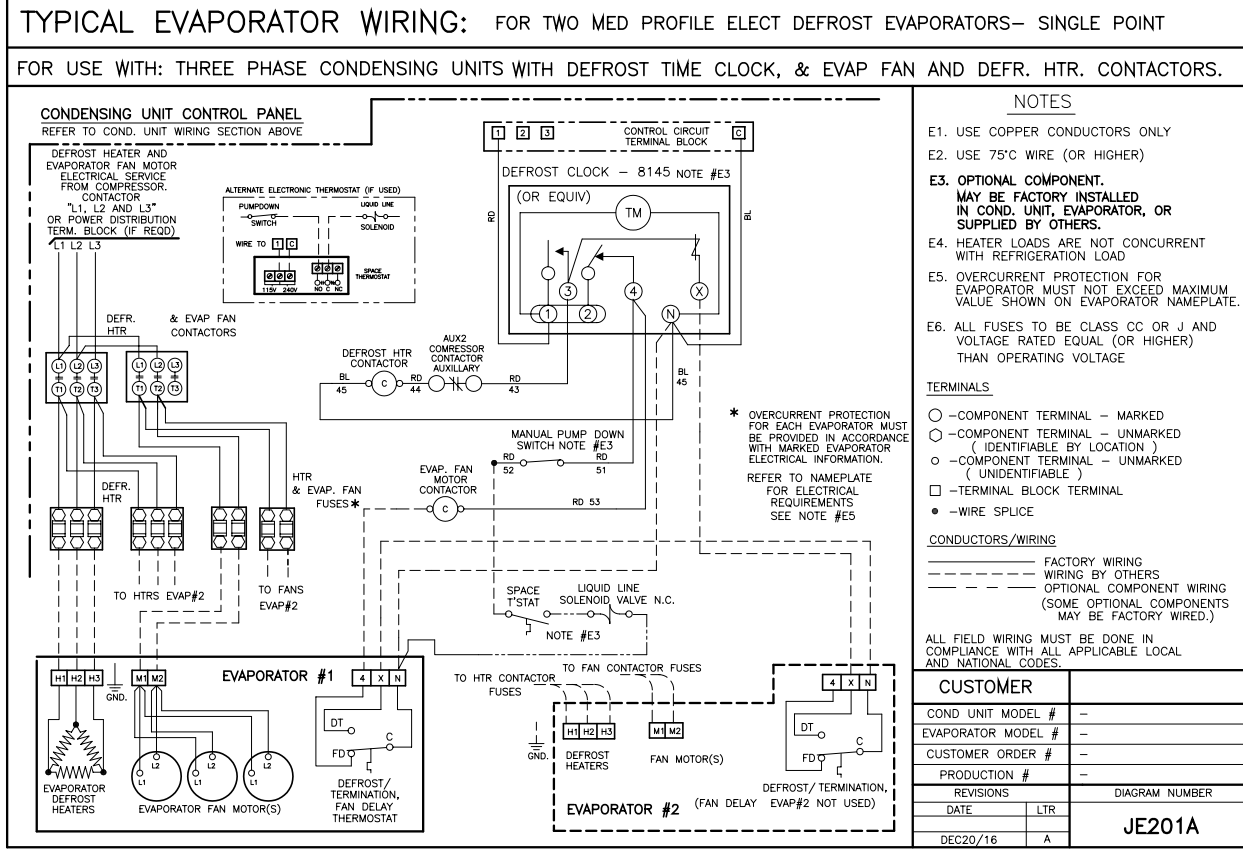
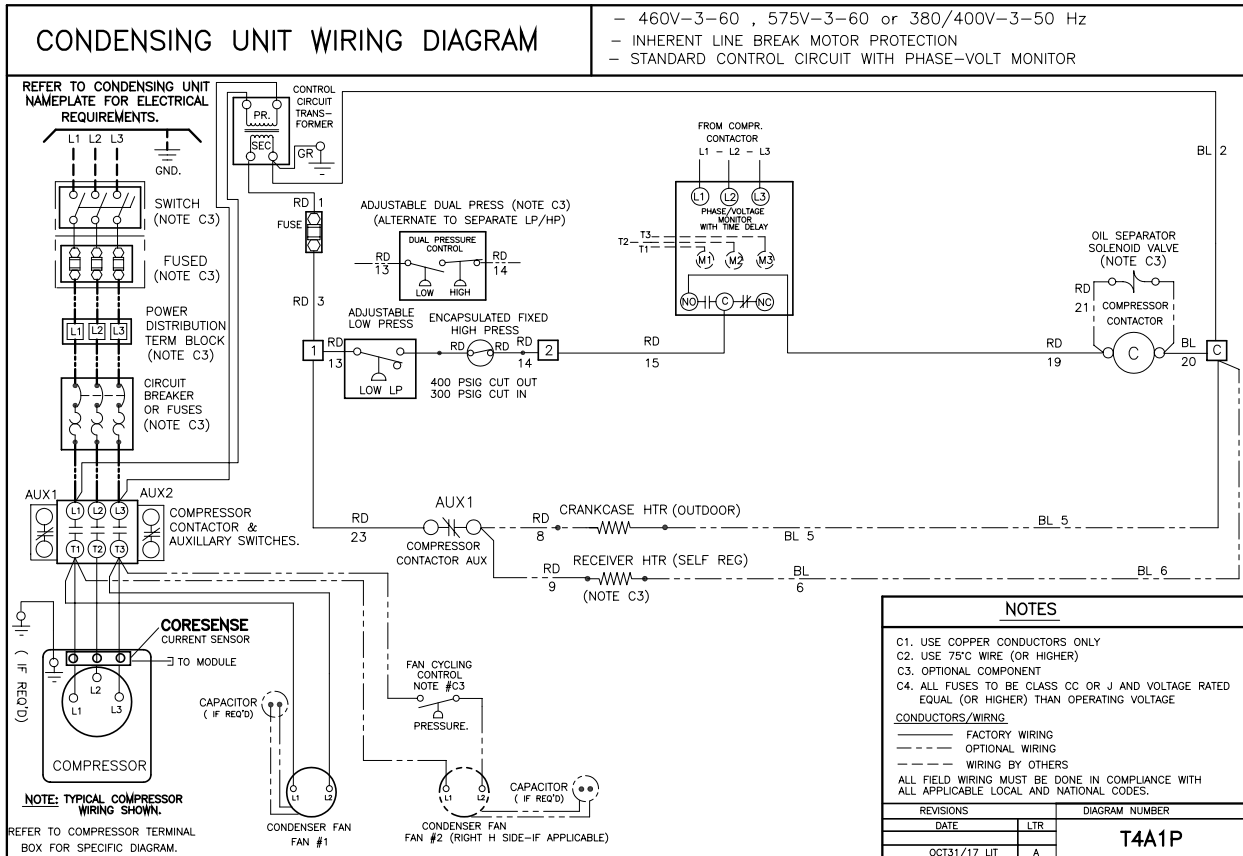

TYPICAL SYSTEM WIRING DIAGRAM

208-230/1/60 Unit with SMARTSPEED™

with 230V Air Defrost Evaporator

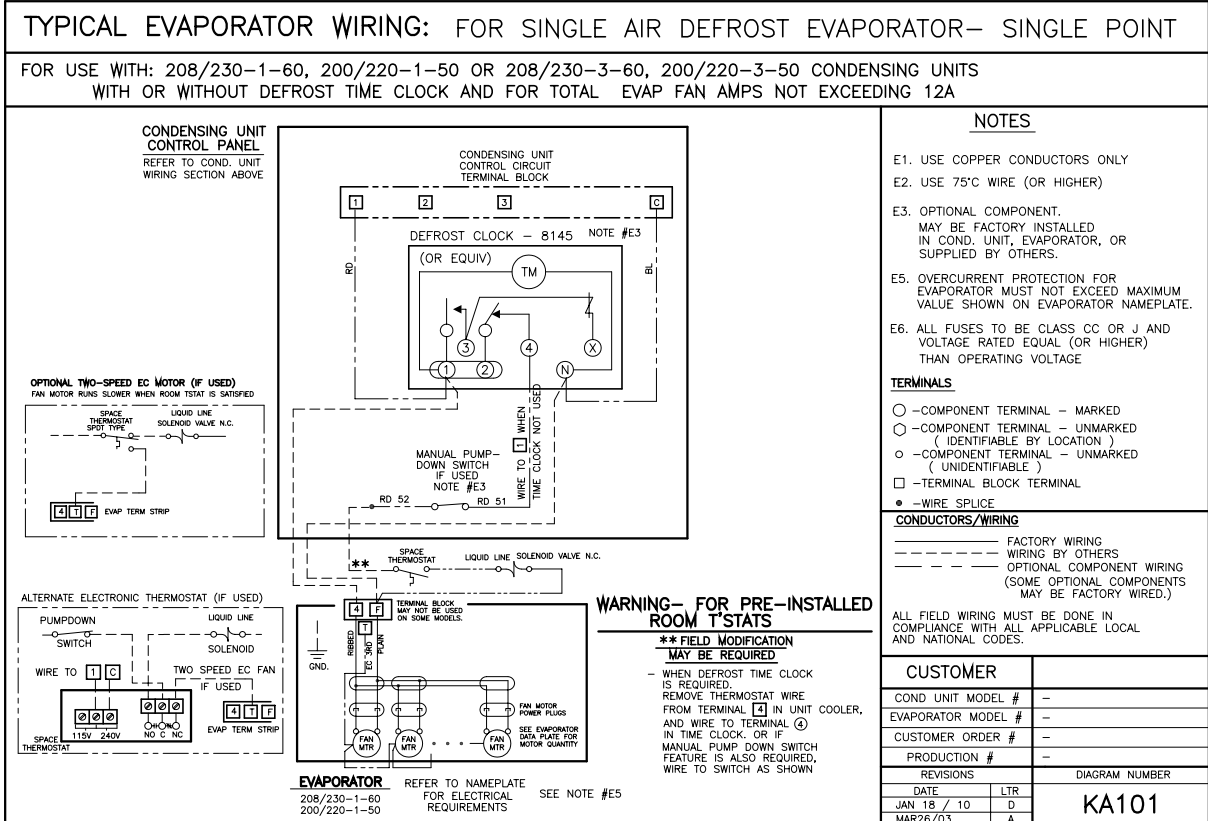
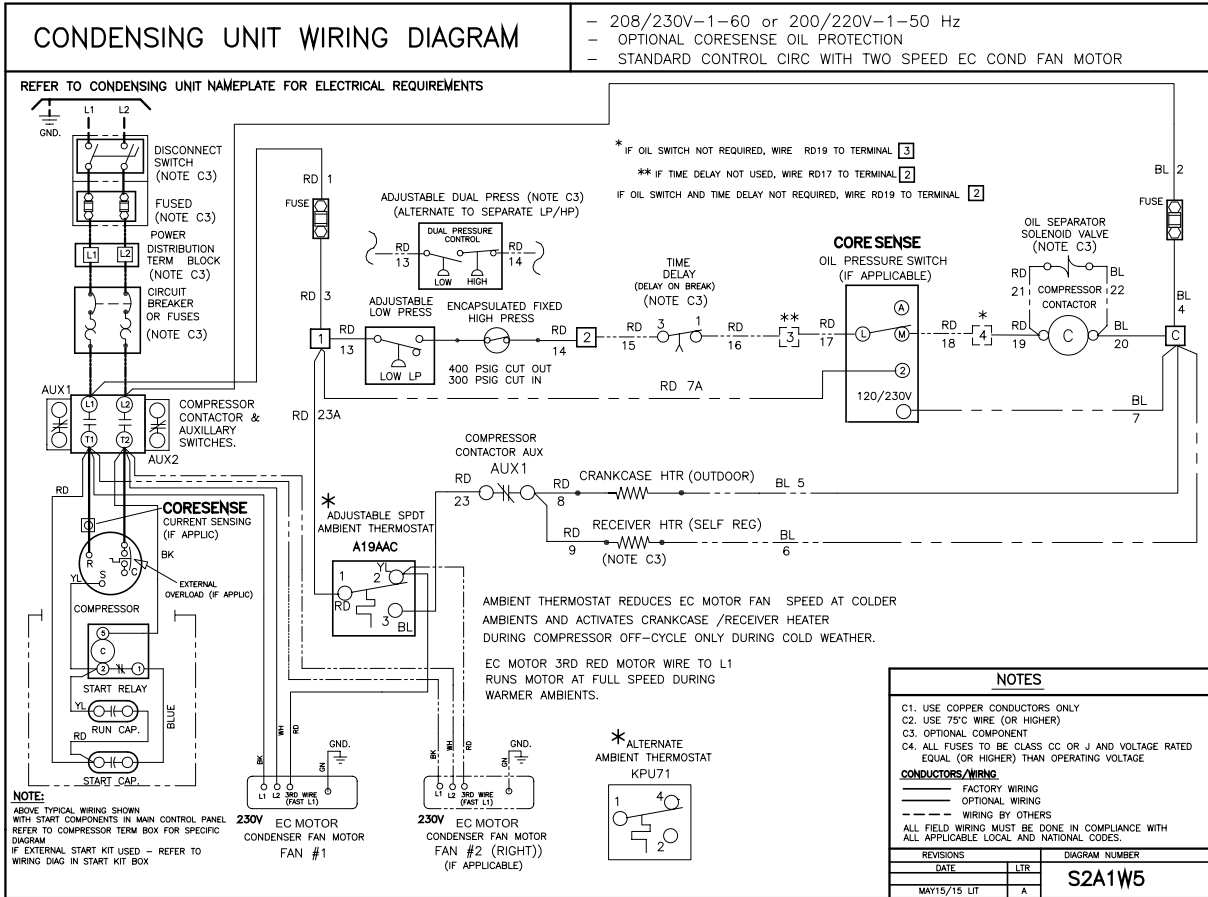

NOTES

System	
Model Number	Date of Start-Up
Serial Number	Service Contractor
Refrigerant	Phone
Electrical Supply	E-Mail

 <p>PRODUCT SUPPORT</p>	<p><i>web:</i> t-rp.com/teh <i>email:</i> smcu@t-rp.com <i>call:</i> 1-844-893-3222 x521</p>
--	---

 <p>TROUBLESHOOTING</p>	<p><i>email:</i> troubleshooting@t-rp.com <i>call:</i> 1-844-893-3222 x529</p>
--	--

 <p>SERVICE PARTS</p>	<p><i>web:</i> t-rp.com/parts <i>email:</i> parts@t-rp.com <i>call:</i> 1-844-893-3222 x521</p>
--	---

 <p>WARRANTY</p>	<p><i>web:</i> t-rp.com/warranty <i>email:</i> warranty@t-rp.com <i>call:</i> 1-844-893-3222 x501</p>
--	---

 <p>ORDERS</p>	<p><i>email:</i> orders@t-rp.com <i>call:</i> 1-844-893-3222 x501</p>
---	--

 <p>SHIPPING</p>	<p><i>email:</i> shipping@t-rp.com <i>call:</i> 1-844-893-3222 x503</p>
---	--

		
<p>Trenton Refrigeration Brantford, ON • Longview, TX 1-800-463-9517 info@t-rp.com www.t-rp.com</p>		