



High Profile Evaporator

60
Hz

PRODUCT DATA & INSTALLATION

Bulletin T30-THPA-PDI-6
Part # 1081586

High & Medium Temperature

Air Defrost

Electrical Power:
208-230/3/60, 460/3/60, 575/3/60

| | | |
|--|---|-----------|
| | PRODUCT SUPPORT | scan: |
| | web: www.t-rp.com/thp | |
| | email: evaps@t-rp.com | |
| | call: 1-844-893-3222 x520 | |

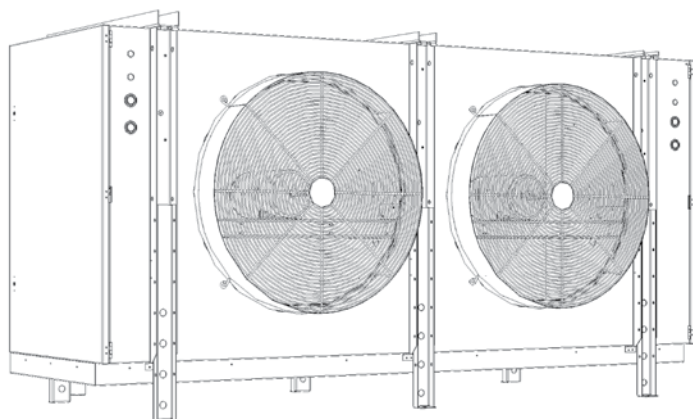

INCLUDES RATINGS FOR
LOW GWP
REFRIGERANTS

ESP+
see page 8 for details

CONTENTS

| | Page |
|--|---------|
| Nomenclature..... | 2 |
| Features & Options..... | 2 |
| Capacity Data..... | 3 |
| Electrical Data..... | 4 |
| Wiring Diagrams..... | 5 - 7 |
| Wiring Diagrams - Models with ESP+ | 8 - 12 |
| Dimensional Data..... | 13 - 14 |
| Specifications..... | 14 |
| Installation Instructions..... | 15 |
| Maintenance | 16 |
| Project Information | 18 |
| Product Support Resources: Service Parts, Troubleshooting, Warranty, etc. | 19 |
| “As Built” Service Parts List..... | BACK |

NOMENCLATURE

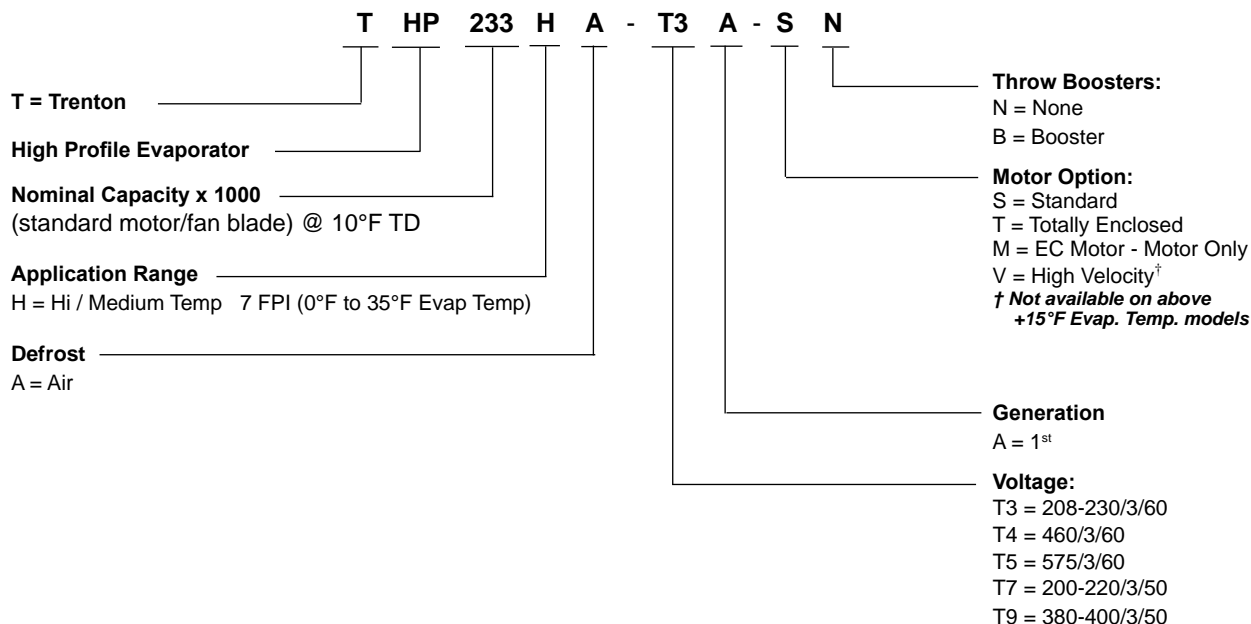

STANDARD FEATURES

- Compatible with Low GWP Refrigerants
- Heavy gauge textured aluminum cabinet with galvanized steel hangers, support channels and end plates
- Hinged access panels with removable hinge pins and captive fasteners.
- Hinged drain pan with removable hinge pins
- Rugged heavy-gauge galvanized steel rail motor mount / support.
- Stackable design
- Schrader fitting and external equalizer line.
- Factory installed solenoid valve wire harness
- Unit shipped upright for convenient handling and quick installation.

AVAILABLE OPTIONS

- Factory mounted TX valve, solenoid valve and thermostat
- Throw boosters
- Insulated drain pan
- EC motors available in two speed or variable speed (Title 24) operation, or controls by others
- **ESP+ Intuitive Evaporator Control Technology. See page 8**
- Totally Enclosed motors
- Optional fin spacing
- Optional fin materials
- Optional coil coating

High and Medium Temperature Models - Capacity @ 7 F.P.I.

| High/Med. Temp. Models THP | | 073HA | 086HA | 113HA | 130HA | 154HA | 170HA | 189HA | 233HA | 252HA | 278HA | |
|---------------------------------------|---------------------------------|-----------------|-----------------|-----------------|------------------|------------------|------------------|------------------|------------------|------------------|------------------|---------|
| Capacity BTUH (WATTS) | Evap Temp. 25°F (-4°C) | R407A | 69350 | 81700 | 107350 | 123500 | 146300 | 161500 | 179600 | 221400 | 239400 | 264100 |
| | | R448A | (20313) | (23930) | (31443) | (36173) | (42852) | (47303) | (52590) | (64834) | (70120) | (77355) |
| | | R407C | 65700 | 77400 | 101700 | 117000 | 138600 | 153000 | 170100 | 209700 | 226800 | 250200 |
| | | | (19244) | (22670) | (29788) | (34269) | (40596) | (44814) | (49822) | (61421) | (66430) | (73283) |
| | | R404A | 73000 | 86000 | 113000 | 130000 | 154000 | 170000 | 189000 | 233000 | 252000 | 278000 |
| | | R507 | (21382) | (25189) | (33098) | (38077) | (45107) | (49793) | (55358) | (68246) | (73811) | (81426) |
| | R22 | 69350 | 81700 | 107350 | 123500 | 146300 | 161500 | 179600 | 221400 | 239400 | 264100 | |
| | | (20313) | (23930) | (31443) | (36173) | (42852) | (47303) | (52590) | (64834) | (70120) | (77355) | |
| | R134a | 65700 | 77400 | 101700 | 117000 | 138600 | 153000 | 170100 | 209700 | 226800 | 250200 | |
| | | (19244) | (22670) | (29788) | (34269) | (40596) | (44814) | (49822) | (61421) | (66430) | (73283) | |
| Air Flow | CFM (L/S) | 16400 (7740) | 15200 (7174) | 15600 (7362) | 22800 (10760) | 24700 (11657) | 23500 (11091) | 25400 (11987) | 35600 (16801) | 33800 (15952) | 31000 (14630) | |
| Refrigerant ** Charge R407A | LB. (KG) | 22 (10) | 30 (14) | 44 (20) | 44 (20) | 55 (25) | 66 (30) | 97 (44) | 108 (49) | 130 (59) | 173 (78) | |

Capacities rated using 10°F (5.6°C) TD & 100°F (38°C) liquid temperature.

Capacities at other TD within a range of 8 to 15 °F (4.4 to 8.3°C) are directly proportional to TD, or use formula: Capacity = Rated capacity ÷ 10 x TD.

For capacities at TD outside of range 8 to 15 °F (4.4 to 8.3°C), or liquid temperature lower than 75°F (24°), consult factory.

Capacities for R448A, R407A and R407C are based on mean temperature. Mean temperature is the average temperature between the saturated suction temperature and the temperature feeding the evaporator. For dew point ratings, consult factory.

Derate capacity by 0.92 and CFM by .85 for Throw Booster Option.

For R449A, use R448A data.

**** REFRIGERANT CHARGE CONVERSION FACTORS**

| R448A | R407C | R404A | R507 | R22 | R134a |
|--------------|--------------|--------------|-------------|------------|--------------|
| 0.96 | 0.99 | 0.92 | 0.93 | 1.02 | 1.03 |

Average Air Throw - ft (m)†

| STANDARD FAN AND MOTOR | OPTIONAL THROW BOOSTER |
|---------------------------|---------------------------|
| 110 (33) | 150 (46) |

† Measured in open space. Actual throw may be less in real applications.

208-230/3/60

| MODEL THP | FAN MOTOR QTY | HP | STANDARD | | | | ECM * | | | |
|--------------|---------------------|-----|-----------------------|-------|-------------------------------|------------------------|-----------------------|-------|-------------------------------|------------------------|
| | | | MOTOR FLA TOTAL | WATTS | MIN. CIRC. AMPACITY (A) | MAX. FUSE (AMPS) | MOTOR FLA TOTAL | WATTS | MIN. CIRC. AMPACITY (A) | MAX. FUSE (AMPS) |
| 073HA-T3A | 2 | 1 | 9.6 | 2200 | 10.8 | 15 | 12.4 | 1740 | 14 | 20 |
| 086HA-T3A | 2 | 1 | 9.6 | 2200 | 10.8 | 15 | 12.4 | 1740 | 14 | 20 |
| 113HA-T3A | 2 | 1.5 | 11.2 | 2880 | 15.1 | 20 | 12.4 | 2560 | 14 | 20 |
| 130HA-T3A | 3 | 1 | 14.4 | 3300 | 15.6 | 20 | 18.6 | 2610 | 20.2 | 25 |
| 154HA-T3A | 3 | 1.5 | 16.8 | 4320 | 20.1 | 25 | 18.6 | 3840 | 20.2 | 25 |
| 170HA-T3A | 3 | 1.5 | 16.8 | 4320 | 20.1 | 25 | 18.6 | 3840 | 20.2 | 25 |
| 189HA-T3A | 3+ | 1.5 | 16.8 | 4320 | 20.1 | 25 | 18.6 | 3840 | 20.2 | 25 |
| 233HA-T3A | 4 | 1.5 | 22.4 | 5760 | 30.1 | 35 | 24.8 | 5120 | 30.1 | 35 |
| 252HA-T3A | 4 | 1.5 | 22.4 | 5760 | 30.1 | 35 | 24.8 | 5120 | 30.1 | 35 |
| 278HA-T3A | 4 | 1.5 | 22.4 | 5760 | 30.1 | 35 | 24.8 | 5120 | 30.1 | 35 |

460/3/60

| MODEL THP | FAN MOTOR QTY | HP | STANDARD | | | | ECM * | | | |
|--------------|---------------------|-----|-----------------------|-------|-------------------------------|------------------------|-----------------------|-------|-------------------------------|------------------------|
| | | | MOTOR FLA TOTAL | WATTS | MIN. CIRC. AMPACITY (A) | MAX. FUSE (AMPS) | MOTOR FLA TOTAL | WATTS | MIN. CIRC. AMPACITY (A) | MAX. FUSE (AMPS) |
| 073HA-T4A | 2 | 1 | 4.8 | 2200 | 5.4 | 15 | 6.2 | 1740 | 7 | 15 |
| 086HA-T4A | 2 | 1 | 4.8 | 2200 | 5.4 | 15 | 6.2 | 1740 | 7 | 15 |
| 113HA-T4A | 2 | 1.5 | 5.6 | 2980 | 6.3 | 15 | 6.2 | 2560 | 7 | 15 |
| 130HA-T4A | 3 | 1 | 7.2 | 3300 | 7.8 | 15 | 9.3 | 2610 | 10.1 | 15 |
| 154HA-T4A | 3 | 1.5 | 8.4 | 4470 | 9.1 | 15 | 9.3 | 3840 | 10.1 | 15 |
| 170HA-T4A | 3 | 1.5 | 8.4 | 4470 | 9.1 | 15 | 9.3 | 3840 | 10.1 | 15 |
| 189HA-T4A | 3+ | 1.5 | 8.4 | 4470 | 9.1 | 15 | 9.3 | 3840 | 10.1 | 15 |
| 233HA-T4A | 4 | 1.5 | 11.2 | 5960 | 15.1 | 20 | 12.4 | 5120 | 15.1 | 20 |
| 252HA-T4A | 4 | 1.5 | 11.2 | 5960 | 15.1 | 20 | 12.4 | 5120 | 15.1 | 20 |
| 278HA-T4A | 4 | 1.5 | 11.2 | 5960 | 15.1 | 20 | 12.4 | 5120 | 15.1 | 20 |

575/3/60

| MODEL THP | FAN MOTOR QTY | HP | STANDARD | | | | ECM * | | | |
|--------------|---------------------|-----|-----------------------|-------|-------------------------------|------------------------|-----------------------|-------|-------------------------------|------------------------|
| | | | MOTOR FLA TOTAL | WATTS | MIN. CIRC. AMPACITY (A) | MAX. FUSE (AMPS) | MOTOR FLA TOTAL | WATTS | MIN. CIRC. AMPACITY (A) | MAX. FUSE (AMPS) |
| 073HA-T5A | 2 | 1 | 4.8 | 2180 | 5.4 | 15 | NA | NA | NA | NA |
| 086HA-T5A | 2 | 1 | 4.8 | 2180 | 5.4 | 15 | NA | NA | NA | NA |
| 113HA-T5A | 2 | 1.5 | 4.6 | 2860 | 5.2 | 15 | NA | NA | NA | NA |
| 130HA-T5A | 3 | 1 | 7.2 | 3270 | 7.8 | 15 | NA | NA | NA | NA |
| 154HA-T5A | 3 | 1.5 | 6.9 | 4290 | 7.5 | 15 | NA | NA | NA | NA |
| 170HA-T5A | 3 | 1.5 | 6.9 | 4290 | 7.5 | 15 | NA | NA | NA | NA |
| 189HA-T5A | 3+ | 1.5 | 6.9 | 4290 | 7.5 | 15 | NA | NA | NA | NA |
| 233HA-T5A | 4 | 1.5 | 9.2 | 5720 | 9.8 | 15 | NA | NA | NA | NA |
| 252HA-T5A | 4 | 1.5 | 9.2 | 5720 | 9.8 | 15 | NA | NA | NA | NA |
| 278HA-T5A | 4 | 1.5 | 9.2 | 5720 | 9.8 | 15 | NA | NA | NA | NA |

NOTES:

* = data is same for either "E" or "M" models (see nomenclature, page 2)

3+ indicates 3-fan "long" configuration (see dimensional data for details)

WIRING DIAGRAM
STANDARD UNITS

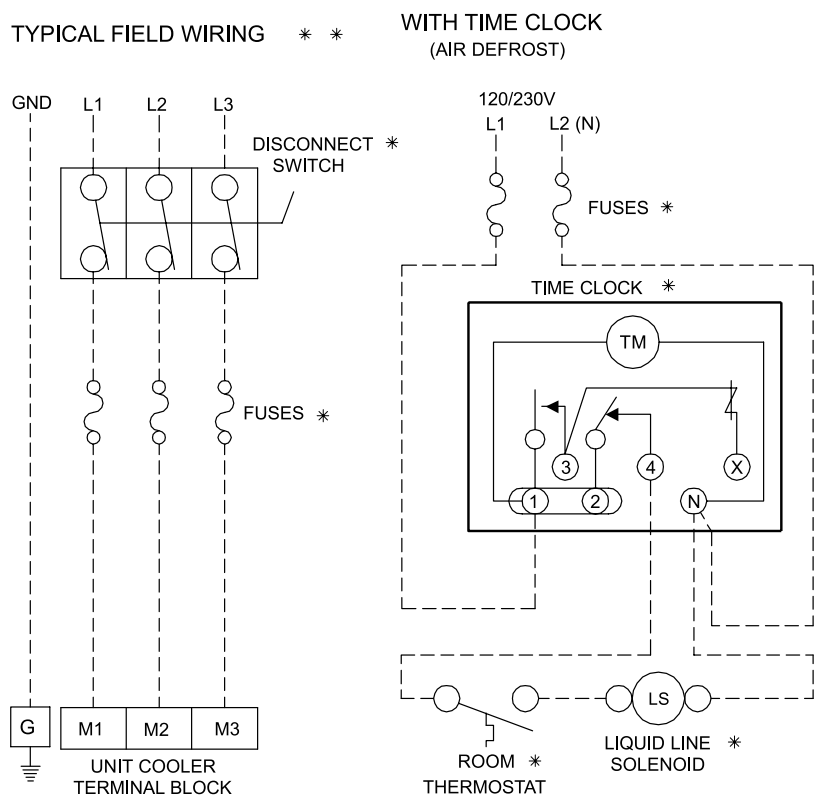
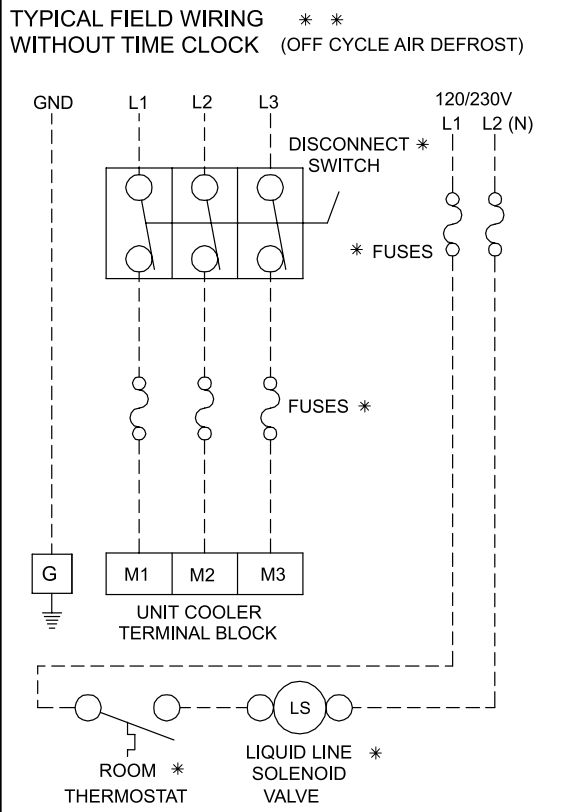
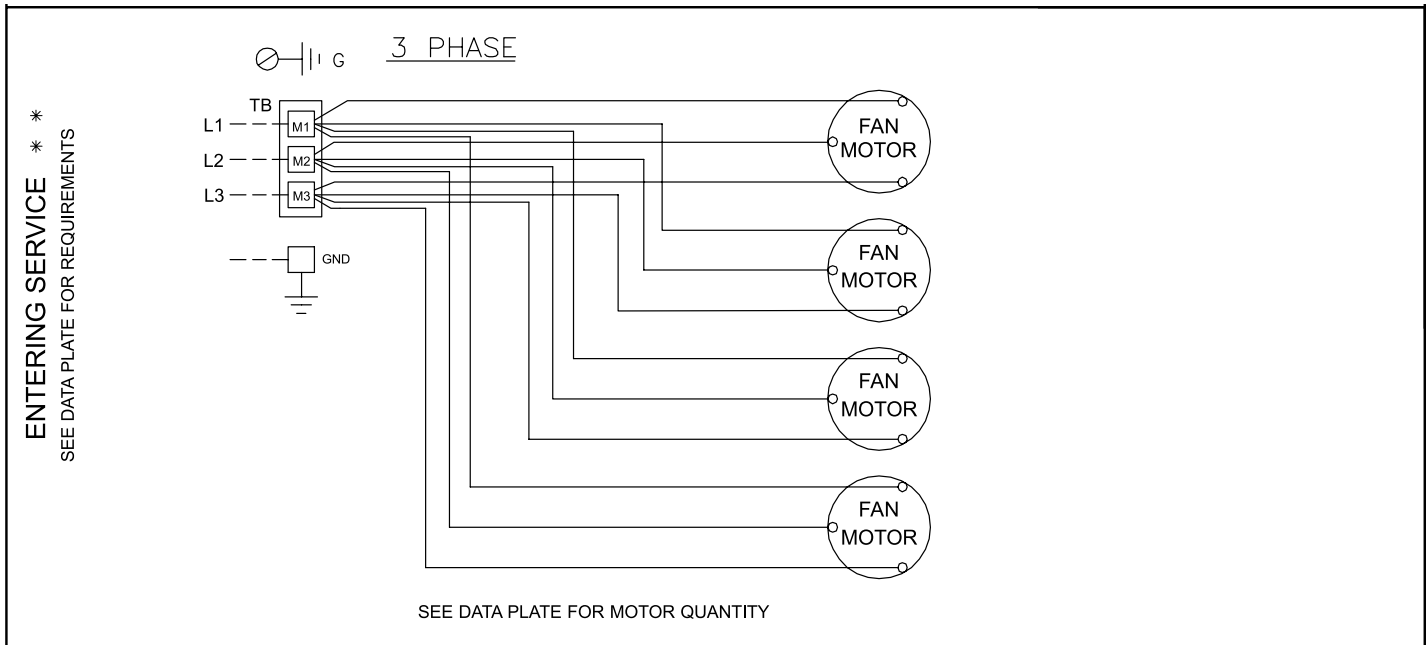

NOTES

- * COMPONENTS BY OTHERS
- FACTORY WIRING
- WIRING BY OTHERS
- * * ALL FIELD WIRING TO BE IN COMPLIANCE WITH ALL APPLICABLE LOCAL AND NATIONAL CODES.

1080875-B

WIRING DIAGRAM

"E" - EC Motor - Packaged Assembly

E - EC MOTOR - Packages Assembly

TYPICAL UNIT COOLER WIRING DIAGRAM - AIR DEFROST AND TWO-SPEED WITH SYS 450

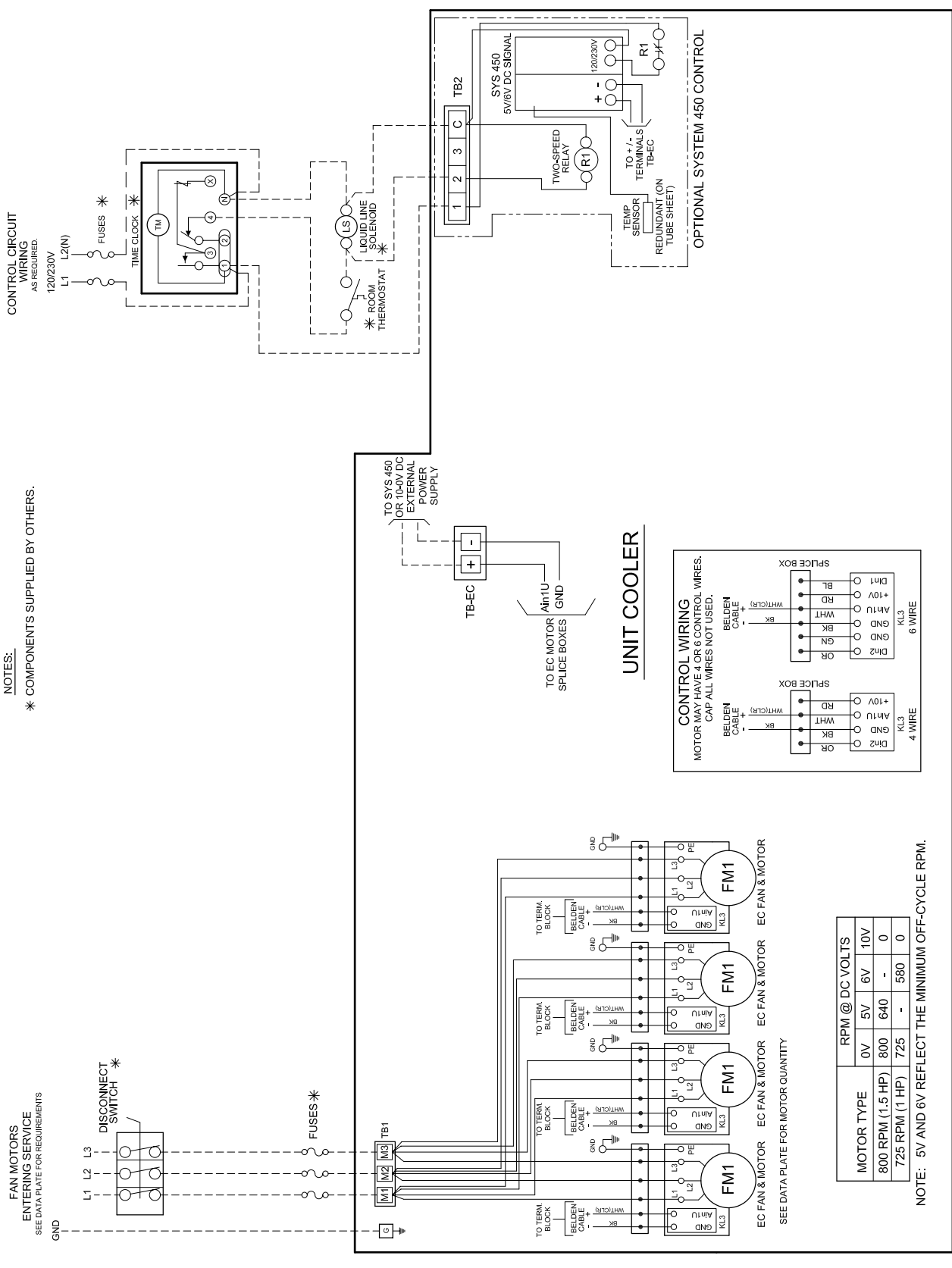

WIRING DIAGRAM

“M” - EC Motor - Motor Only (Conventional Shafted Style Motor)

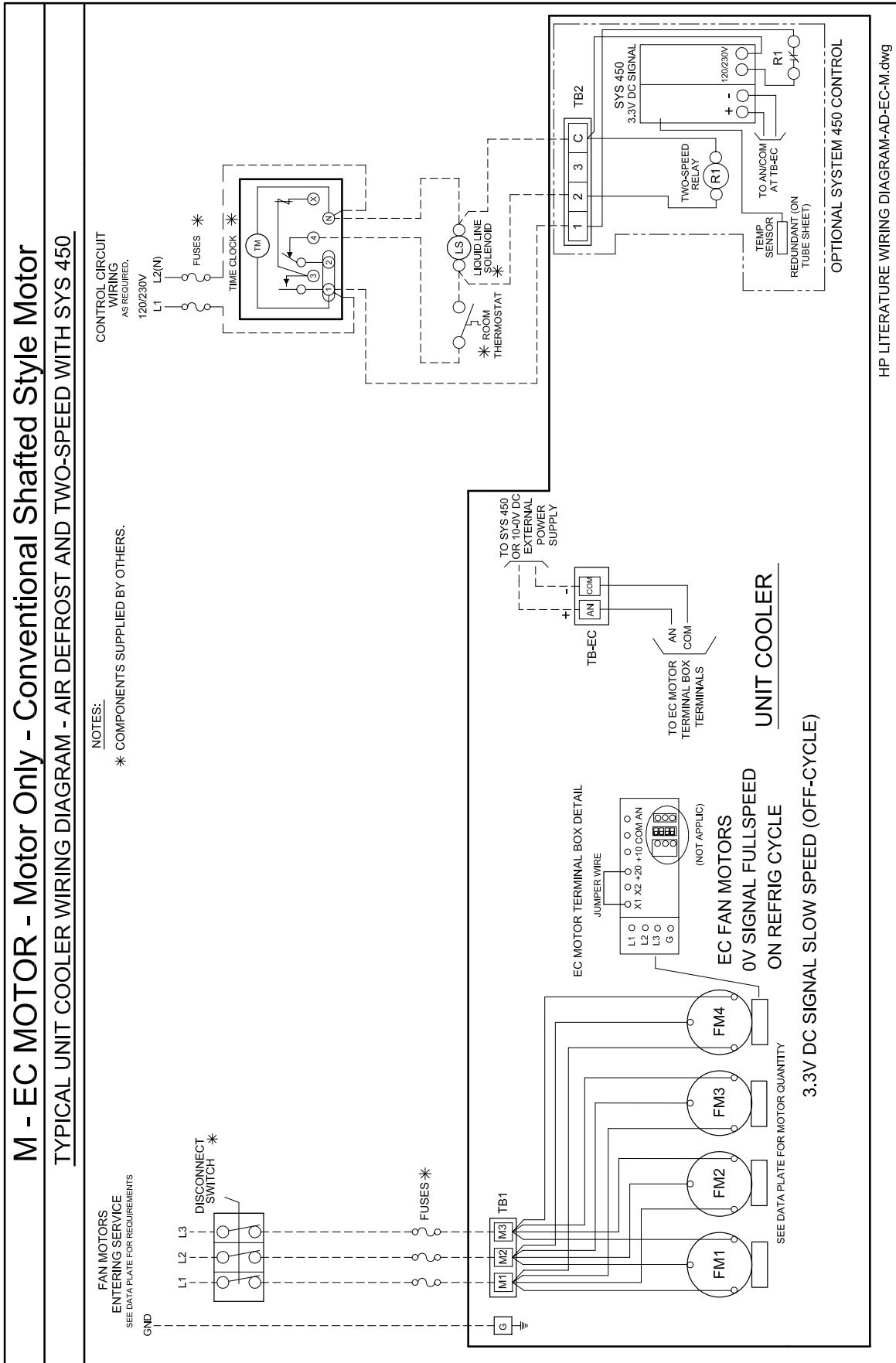

HPA

ESP+

60Hz

INTUITIVE EVAPORATOR CONTROL TECHNOLOGY

What is ESP+?

Trenton Refrigeration's ESP+ intuitive evaporator control technology is designed to replace traditional electro-mechanical refrigeration controls typically used on medium and low temperature applications. By combining award winning adaptive technology along with an electronic expansion valve, Trenton Refrigeration continues Leading The Way with innovative, state-of-the-art designs.

Installing an evaporator utilizing the ESP+ intuitive evaporator control technology is simple. Two pipes, two wires and you're done. No interconnecting control wiring between the evaporator and the condensing unit is required.

- Quick simple installation
- Improved evaporator performance by minimizing excessive frost on the evaporator
 - Eliminates ice build up on surfaces and product
 - Energy savings through evaporator fan management
- Energy savings with reduction in the number of defrost cycles
 - Defrost heater management
- Improved system diagnostics and service through advanced alarm notification text/email
 - Remote monitoring & system control
 - User friendly interface
- Precise temperature control for prolonged product shelf life
- Improved product integrity with less potential for spoilage
- Downloadable data provides system history for prior 30 days
- Remotely view and change system parameters and alarm settings
 - Manually control system
 - Easily troubleshoot issues

ESP+ controls:

- Box Temperature - Superheat
- Defrost Initiation - Defrost Termination - Fan Motors
- Defrost Heater (Electric Defrost Models)

Plus - User can access operating data directly from the system interface

15-20% System Energy Savings over a Properly Commissioned System!

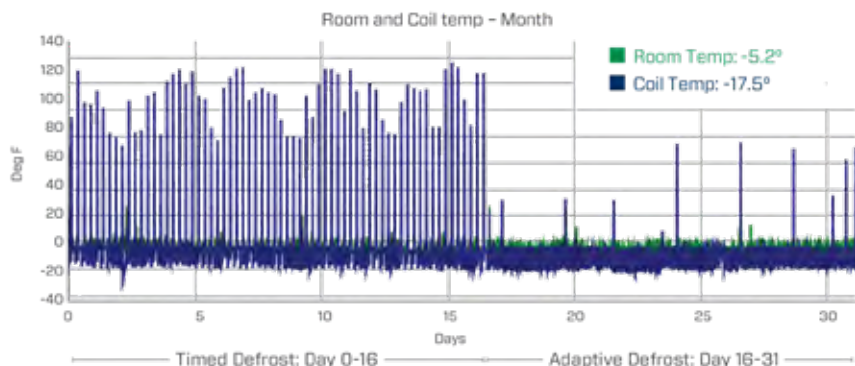

86% Fewer Defrost Cycles*

- Enhanced system performance
- Energy Savings
- Improved product integrity

* Data may vary depending on application

Visit www.t-rp.com/esp for details

2 Fan Models

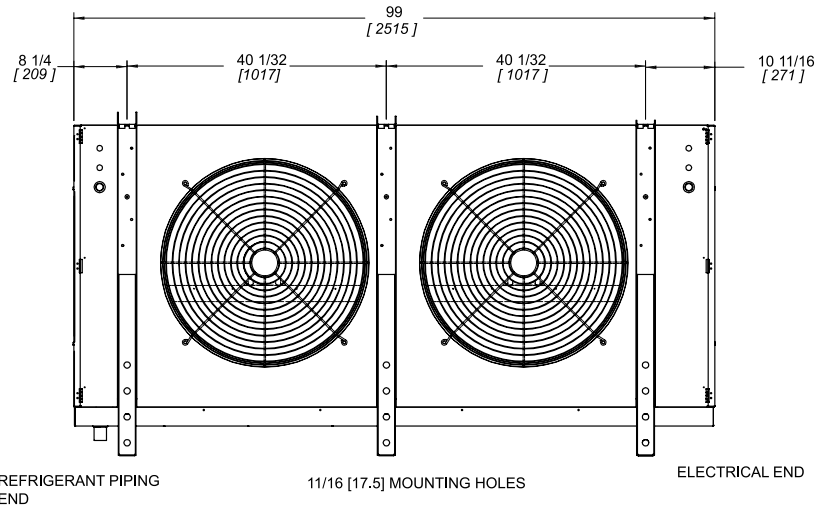
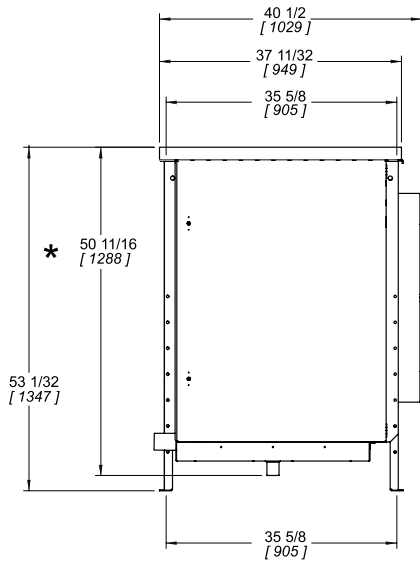

3 Fan Models

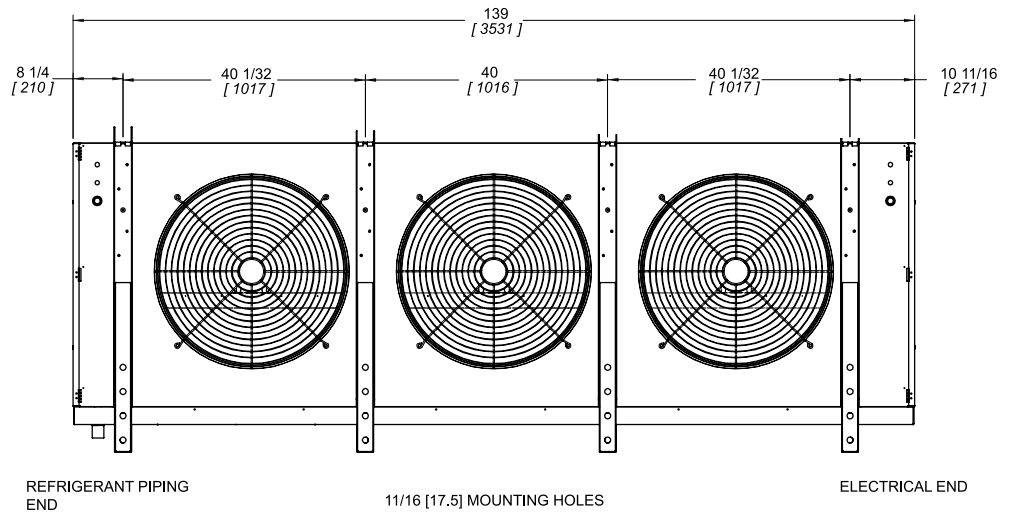
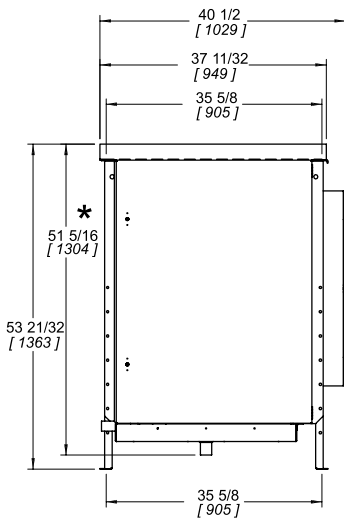

Drain connections 1-1/4" FPT.

The installation and start-up of evaporators should only be performed by qualified refrigeration mechanics. This equipment should be installed in accordance with all applicable codes, ordinances and local by-laws

INSPECTION

Inspect all equipment before unpacking for visible signs of damage or loss. Check shipping list against material received to ensure shipment is complete.

IMPORTANT: Remember, you, the consignee, must make any claim necessary against the transportation company. Shipping damage or missing parts, when discovered at the outset, will prevent later unnecessary and costly delays.

If damage or loss during transport is evident, make claim to carrier, as this will be their responsibility, not the manufacturer's.

Should carton be damaged, but damage to equipment is not obvious, a claim should be filed for "concealed damage" with the carrier.

IMPORTANT: The electrical characteristics of the unit should be checked at this time to make sure they correspond to those ordered and to electrical power available at the job site. Save all shipping papers, tags and instruction sheets for reference by installer and owner.

LOCATION

The unit location in the room should be selected to ensure uniform air distribution throughout the entire space to be refrigerated. Be sure that the unit does not draw air in, or blow directly out, through an opened door and that the product does not obstruct the free circulation of air.

Consideration should be given to the coil location in order to minimize the piping run length to the condensing unit and floor drain

CLEARANCES

This evaporator draws air through the coil and discharges air from the fan side, and thus adequate clearance should be made on the entering face of the coil to ensure even unrestricted air flow through the coil. This distance should be equal to the height of the coil or more.

Ensure enough room is left at the ends of the coil for servicing.

MOUNTING

This evaporator is supplied with shipping legs to allow units to be shipped in an upright position. Units can be lifted into place with shipping skid attached to mounting legs.

Hanger brackets take up to 5/8" (15.9 mm) hanger rods. After the evaporator is hung in place, remove the bolts attaching the skid to the legs.

DRAIN LINE

If the evaporator is mounted flush to ceiling, the staggered hanger will provide a positive pitch for drainage.

If units are suspended below the ceiling, the installer must provide adequate pitch to the unit by adjusting the location of the hanger rod nuts.

Note: Check for adequate drainage by pouring water into the drain pan.

Ensure that the drain pan has sufficient slope for proper drainage (prevention of ice build up / blockage in pan).

Insulated copper tube should be run from the drain connection, sloping at least 4" (102mm) per foot. A trap located outside of the room should be provided to prevent warm air entering through the tubing. Connection should be made to proper drainage facilities that comply with local regulations.

If room temperatures are below freezing, it is necessary to heat the drain line to prevent condensate from freezing in the drain line. Electric heating cable or electric tape (by others) is used

for this purpose. The drain line heater should be connected for continuous operation; it is also recommended that the drain line be insulated. A heat output of 20 watts per lineal foot of 1" (25mm) drain line in a 0°F (-18 °C) room is usually satisfactory. 115 volt cable and tape is available from your local refrigeration wholesaler. Two 115 volts heaters (by others) of the same wattage may be wired in series for use on 230 volt system

PIPING

Refrigerant line sizes are important and may not be the same size as the coil connections (depends on the length of run). If in doubt, consult "Recommended refrigerant line sizes" charts.

WIRING

Wire system in accordance with governing standards and local codes. Enclosed typical wiring diagrams are for reference only. Refer to unit data plate for operating current, minimum ampacity and maximum fuse sizing for fan motors.

NOTE: Electrical wiring is to be sized in accordance with minimum ampacity rating.

For ease of identifying the proper wiring terminals, unit wiring is colour coded and terminal block connections are identified. When **fan delay thermostats** (combination fan delay and defrost termination) are installed, on start-up, the fans do not operate until the coil temperature is reduced to approximately 20°F (-6.7°C). It is normal for the fans to cycle a few times until the room temperature is brought down. At higher evaporating temperatures this control is of an adjustable type, and proper adjustment is required.

The **defrost termination control** is adjustable and may be set at a minimum of 40°F (4.4°C) (fully CW) to a maximum of 75°F (23.8°C) (fully CCW). Normal setting is 55°F (12.8°C). This can be increased if the defrost heaters are terminated too soon (frost still left) or if terminated too long (steaming of coil). Time clock should be set for a fail-safe termination of approximately 45 minutes.

A hinged end panel provides quick access to the electrical compartment.

SYSTEM CHECK

Before Start-Up:

1. All wiring should be in accordance with local codes.
2. All refrigerant lines should be properly sized.
3. Electric defrost systems should include a liquid line solenoid valve.
4. Thorough evacuation and dehydration has been performed.
5. The suction, discharge and receiver service valves must be open.
6. The system should include a liquid line drier moisture indicator and suction filter.
7. Pour enough water into the drain pan to allow a good check on drainage and seal the trap.

After Start-Up:

1. If necessary, temporarily by-pass fan delay control to run fans until room temp is lowered. (Run jumper wire from terminal N to F on circuit terminal block).
2. Check the compressor oil level to ensure the correct oil charge.
3. Be sure that the expansion valve is properly set to provide the correct amount of superheat (should be around 70% of operating T.D.)
4. Heavy moisture loads are usually encountered when starting the system for the first time. If the coil temperature is below freezing, this will cause a rapid build-up of frost on the coil. During the initial pull down, frost build-up should be watched and defrosted manually as required.
5. Check for proper evaporator fan blade rotation.

THPA

MAINTENANCE

60Hz

1. Periodic checking and cleaning of the coil surface when necessary should be done, using a whisk or brush. Drain pans are hinged to provide convenient access to the inside coil surface (except hot gas loop pans).
2. Ensure coil and pan does not have any excessive ice build-up from improper defrost operation. Any build-up of ice can cause fins and refrigerant tubes to be crushed. When replacing heater elements, first remove heater slot covers and heater clips
3. Motors are permanently lubricated type and require no further lubrication.



Visit
www.t-rp.com/esp
for Quick Start Guide, Operation Manual, etc

NOTE: Models in this document are not certified to DOE/NRCAN efficiency standards and should not be used for coolers or freezers less than 3000 sq.ft.

THPA

NOTES

60Hz

| | |
|-------------------|--------------------|
| System | |
| Model Number | Date of Start-Up |
| Serial Number | Service Contractor |
| Refrigerant | Phone |
| Electrical Supply | E-Mail |

| | |
|---|---|
|  <p>PRODUCT SUPPORT</p> | <p><i>web: www.t-rp.com/thp</i> <i>email: evaps@t-rp.com</i> <i>call: 1-844-893-3222 x520</i></p> |
|  <p>TROUBLESHOOTING</p> | <p><i>email: troubleshooting@t-rp.com</i> <i>call: 1-844-893-3222 x529</i></p> |
|  <p>SERVICE PARTS</p> | <p><i>web: www.t-rp.com/parts</i> <i>email: parts@t-rp.com</i> <i>call: 1-844-893-3222 x520</i></p> |
|  <p>WARRANTY</p> | <p><i>web: www.t-rp.com/warranty</i> <i>email: warranty@t-rp.com</i> <i>call: 1-844-893-3222 x501</i></p> |
|  <p>ORDERS</p> | <p><i>email: orders@t-rp.com</i> <i>call: 1-844-893-3222 x501</i></p> |
|  <p>SHIPPING</p> | <p><i>email: shipping@t-rp.com</i> <i>call: 1-844-893-3222 x503</i></p> |

HOW CAN WE HELP YOU?
visit www.t-rp.com/contact

“AS BUILT” SERVICE PARTS LIST

Service Parts List
Label
To Be Attached
HERE



Trenton Refrigeration
Brantford, ON • Longview, TX
1-800-463-9517 info@t-rp.com www.t-rp.com

