



**PRODUCT DATA & INSTALLATION**

Bulletin T30-TLV-PDI-29e  
Part # 1073478

# TLV Low Velocity Evaporators **60 Hz**

**High Temperature**

35°F (2°C) or Above Box Temperature and

**Medium Temperature**

28°F to 34°F Box Temperature (-2°C to 1°C)

**Defrost Types:**

Air, Electric or Hot Gas Defrost

PRODUCT SUPPORT  
 web: [www.t-rp.com/tlv](http://www.t-rp.com/tlv)  
 email: [evaps@t-rp.com](mailto:evaps@t-rp.com)  
 call: 1-844-893-3222 x520

scan:

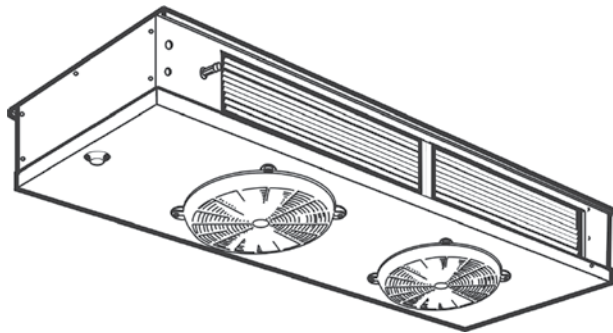

**SMARTSPEED™**  
FAN MOTOR TECHNOLOGY

See Page 14 for details

**ESP+**

see page 19 for details



CONTENTS	PAGE
Nomenclature, Features and Options.....	2
Capacity Data .....	3
Electrical Data .....	4 - 5
Dimensional Data.....	6
Installation Clearances.....	7
Wiring Diagrams - Models with standard PSC Motors .....	8 - 13
Wiring Diagrams - Models with optional EC Motors / <b>SMARTSPEED™</b> .....	14 - 18
Wiring Diagrams - Models with <b>ESP+</b> .....	19 - 23
TXV/ Distributor Nozzle Selection.....	24
Expansion Valve Selections - Models with <b>ESP+</b> .....	25
Defrost Control Positions.....	26
Defrost Kit and Fuse Package Selections / Details .....	27 - 29
Installation Instructions.....	30 - 31
Project Information.....	34
Product Support Resources: Service Parts, Troubleshooting, Warranty, etc.....	35
“As Built” Service Parts List.....	Back

# NOMENCLATURE

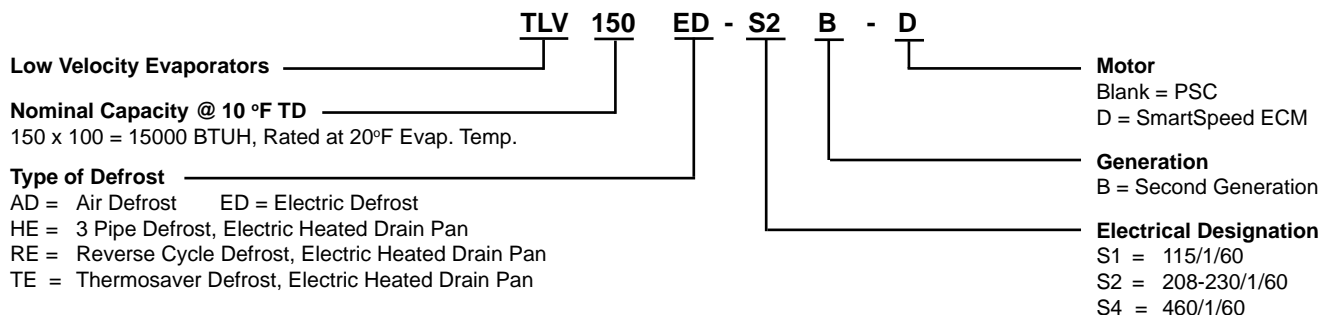

---



---

## STANDARD FEATURES

- Compatible with Low GWP Refrigerants
- Heavy gauge textured aluminum cabinet construction resists scratches/corrosion and minimizes weight for shipment, installation and service.
- High-efficiency PSC motors.
- Specially designed for quiet operation - ideal for prep. rooms.
- Capacity up to 37,000 BTUH nominal.
- Dual refrigeration coils with two-way air distribution reduces air velocities to minimize product dehydration.
- Reduced operating charge with 3/8" OD tubing
- Spacious end compartment allows for easy component installation.
- Attractive and durable high-density polypropylene fan guards.
- Hinged drain pan provides convenient access for cleaning.
- Terminal board allows for easy electrical connections.

---



---

## AVAILABLE OPTIONS

- Factory mounted solenoid valve, TXV and thermostat.
- EC motors with patented SmartSpeed® Technology. See page 14
- **ESP+ Intuitive Evaporator Control Technology.** See page 19
- Painted cabinet
- Corrosion protection: alternate fin materials and coatings
- Additional options available, please contact factory

High Temp. Model TLV		060AD	090AD	120AD	150AD	180AD	220AD	270AD	300AD	340AD	370AD	
Electric Defrost Model TLV		060ED	090ED	120ED	150ED	180ED	220ED	270ED	300ED	340ED	370ED	
Hot Gas Defrost Model TLV		060 <sup>†</sup>	090 <sup>†</sup>	120 <sup>†</sup>	150 <sup>†</sup>	180 <sup>†</sup>	220 <sup>†</sup>	270 <sup>†</sup>	300 <sup>†</sup>	340 <sup>†</sup>	370 <sup>†</sup>	
Capacity BTUH (WATTS)	Evap Temp. 25°F (-4°C)	R407A	5700	8550	11400	14250	17100	20900	25700	28500	32300	35200
		R448A	(1669)	(2503)	(3338)	(4172)	(5007)	(6120)	(7511)	(8345)	(9458)	(10292)
		R407C	5400	8100	10800	13500	16200	19800	24400	27100	30700	33400
		R404A	(1581)	(2372)	(3163)	(3953)	(4744)	(5798)	(7115)	(7906)	(8960)	(9751)
		R507	6000	9000	12000	15000	18000	22000	27000	30000	34000	37000
		R22	(1757)	(2635)	(3514)	(4392)	(5271)	(6442)	(7906)	(8784)	(9956)	(10834)
		R134a	5700	8550	11400	14250	17100	20900	25700	28500	32300	35200
			(1669)	(2503)	(3338)	(4172)	(5007)	(6120)	(7511)	(8345)	(9458)	(10292)
			5400	8100	10800	13500	16200	19800	24300	27000	30600	33300
			(1581)	(2372)	(3163)	(3953)	(4744)	(5798)	(7115)	(7906)	(8960)	(9751)
Air Flow	CFM (L/s)	850 (401)	1120 (529)	1500 (708)	2000 (944)	2530 (1194)	2785 (1314)	3400 (1605)	4000 (1888)	4370 (2062)	4840 (2284)	
Refrigerant ** Charge	Lbs (Kg)	2.6 (1.2)	4.4 (2.0)	6.5 (2.9)	7.3 (3.3)	7.9 (3.6)	10.1 (4.6)	9.9 (4.5)	11.9 (5.4)	15.2 (6.9)	15.2 (6.9)	
Std. Unit Net Weight (w/o Refrigerant)	Lbs (Kg)	90 (41)	105 (48)	139 (63)	158 (72)	220 (100)	235 (107)	257 (117)	270 (123)	280 (127)	290 (132)	

† Refer to Hot Gas Defrost nomenclature and insert appropriate code

NOTE: Defrost heaters can be field converted to operate on 208-230/3/60

Capacities rated using 10°F (5.6°C) TD & 100°F (38°C) liquid temperature.

Capacities at other TD within a range of 8 to 15 °F (4.4 to 8.3°C) are directly proportional to TD, or use formula: Capacity = Rated capacity ÷ 10 x TD.

For capacities at TD outside of range 8 to 15 °F (4.4 to 8.3°C), or liquid temperature lower than 75°F (24°), consult factory.

Capacities for R448A, R407A and R407C are based on mean temperature. Mean temperature is the average temperature between the saturated suction temperature and the temperature feeding the evaporator. For dew point ratings, consult factory.

For R449A, use R448A data.

\*\* REFRIGERANT CHARGE CONVERSION FACTORS

R448A	R407C	R404A	R507	R22	R134a
0.96	0.99	0.92	0.93	1.02	1.03

## Air Defrost Models - 115/1/60

Model TLV	No. of Fans	Standard PSC Motor				Optional SMARTSPEED <sup>®</sup> EC Motor			
		FLA	MCA*	Watts	MOP	FLA	MCA*	Watts	MOP
060AD	1	1.1	1.4	90	15	0.8	1.0	55	15
090AD	1	1.1	1.4	130	15	1.6	2.0	95	15
120AD	2	2.2	2.5	180	15	1.6	1.8	110	15
150AD	2	2.2	2.5	260	15	3.2	3.6	190	15
180AD	3	3.3	3.6	270	15	2.4	2.6	165	15
220AD	3	3.3	3.6	390	15	4.8	5.2	285	15
270AD	3	3.3	3.6	390	15	4.8	5.2	285	15
300AD	4	4.4	4.7	520	15	6.4	6.8	380	15
340AD	4	4.4	4.7	520	15	6.4	6.8	380	15
370AD	5	5.5	5.8	650	15	8.0	8.4	475	15

FLA = Full Load Amps MCA = Minimum Circuit Ampacity MOP = Maximum Over Current Protection

\* Electrical wiring is to be sized in accordance with minimum circuit ampacity

## Air Defrost Models - 208-230/1/60

Model TLV	No. of Fans	Standard PSC Motor				Optional SMARTSPEED <sup>®</sup> EC Motor			
		FLA	MCA*	Watts	MOP	FLA	MCA*	Watts	MOP
060AD	1	0.5	0.6	90	15	0.5	0.6	55	15
090AD	1	0.5	0.6	130	15	1.0	1.3	95	15
120AD	2	1.0	1.1	180	15	1.0	1.1	110	15
150AD	2	1.0	1.1	260	15	2.0	2.3	190	15
180AD	3	1.5	1.6	270	15	1.5	1.6	165	15
220AD	3	1.5	1.6	390	15	3.0	3.3	285	15
270AD	3	1.5	1.6	390	15	3.0	3.3	285	15
300AD	4	2.0	2.1	520	15	4.0	4.3	380	15
340AD	4	2.0	2.1	520	15	4.0	4.3	380	15
370AD	5	2.5	2.6	650	15	5.0	5.3	475	15

FLA = Full Load Amps MCA = Minimum Circuit Ampacity MOP = Maximum Over Current Protection

\* Electrical wiring is to be sized in accordance with minimum circuit ampacity

## Air Defrost Models - 460/1/60

Model TLV	No. of Fans	Standard PSC Motor			
		FLA	MCA*	Watts	MOP
060AD	1	0.3	0.4	90	15
090AD	1	0.3	0.4	130	15
120AD	2	0.6	0.7	180	15
150AD	2	0.6	0.7	260	15
180AD	3	0.9	1.0	270	15
220AD	3	0.9	1.0	390	15
270AD	3	0.9	1.0	390	15
300AD	4	1.2	1.3	520	15
340AD	4	1.2	1.3	520	15
370AD	5	1.5	1.6	650	15

FLA = Full Load Amps MCA = Minimum Circuit Ampacity

MOP = Maximum Over Current Protection

\* Electrical wiring is to be sized in accordance with minimum circuit ampacity

**Electric Defrost Models - 115/1/60**

Model TLV	No. of Fans	Fan Motors								Defrost Heaters			
		Standard PSC Motor				Optional SMARTSPEED <sup>®</sup> EC Motor				Watts	FLA	MCA*	MOP
		FLA	MCA*	Watts	MOP	FLA	MCA*	Watts	MOP				
060ED	1	1.1	1.4	90	15	0.8	1.0	55	15	1880	16.4	20.4	25
090ED	1	1.1	1.4	130	15	1.6	2.0	95	15	1880	16.4	20.4	25

FLA = Full Load Amps MCA = Minimum Circuit Ampacity MOP = Maximum Over Current Protection

\* Electrical wiring is to be sized in accordance with minimum circuit ampacity

**Electric Defrost Models - 208-230/1/60**

Model TLV	No. of Fans	Fan Motors - 208-230/1/60								Defrost Heaters - 208/230/1/60				Defrost Heaters field converted to operate on 208-230/3/60			
		Standard PSC Motor				Optional SMARTSPEED <sup>®</sup> EC Motor				Watts	FLA	MCA*	MOP	Watts	FLA	MCA*	MOP
		FLA	MCA*	Watts	MOP	FLA	MCA*	Watts	MOP								
060ED	1	0.5	0.6	90	15	0.5	0.6	55	15	1880	8.2	10.2	15	1880	4.9	6.1	15
090ED	1	0.5	0.6	130	15	1.0	1.3	95	15	1880	8.2	10.2	15	1880	4.9	6.1	15
120ED	2	1.0	1.1	180	15	1.0	1.1	110	15	3180	13.8	17.3	20	3180	8.5	10.6	15
150ED	2	1.0	1.1	260	15	2.0	2.3	190	15	3180	13.8	17.3	20	3180	8.5	10.6	15
180ED	3	1.5	1.6	270	15	1.5	1.6	165	15	4540	19.7	24.7	25	4540	12.1	15.1	20
220ED	3	1.5	1.6	390	15	3.0	3.3	285	15	4540	19.7	24.7	25	4540	12.1	15.1	20
270ED	3	1.5	1.6	390	15	3.0	3.3	285	15	4540	19.7	24.7	25	4540	12.1	15.1	20
300ED	4	2.0	2.1	520	15	4.0	4.3	380	15	4540	19.7	24.7	25	4540	12.1	15.1	20
340ED	4	2.0	2.1	520	15	4.0	4.3	380	15	5580	24.3	30.3	35	5580	14.9	18.6	20
370ED	5	2.5	2.6	650	15	5.0	5.3	475	15	5580	24.3	30.3	35	5580	14.9	18.6	20

FLA = Full Load Amps MCA = Minimum Circuit Ampacity MOP = Maximum Over Current Protection

\* Electrical wiring is to be sized in accordance with minimum circuit ampacity

**Hot Gas Defrost Models - 115/1/60**

Model TLV	No. of Fans	Standard PSC Motor					Optional SMARTSPEED <sup>®</sup> EC Motor				
		Drain Pan Heater Watts	Heater Amps	Fan Motor FLA	MCA*	MOP	Drain Pan Heater Watts	Heater Amps	Fan Motor FLA	MCA*	MOP
060 HE/RE	1	580	5.0	1.1	6.3	15	580	5.0	0.8	6.6	15
090 HE/RE	1	580	5.0	1.1	6.3	15	580	5.0	1.6	6.6	15
120 HE/RE	2	580	5.0	2.2	6.3	15	580	5.0	1.6	6.6	15
150 HE/RE	2	580	5.0	2.2	6.3	15	580	5.0	3.2	6.6	15
180 HE/RE	3	820	7.1	3.3	8.9	15	820	7.1	2.4	9.4	15
220 HE/RE	3	820	7.1	3.3	8.9	15	820	7.1	4.8	9.4	15
270 HE/RE	3	820	7.1	3.3	8.9	15	820	7.1	4.8	9.4	15
300 HE/RE	4	820	7.1	4.4	8.9	15	820	7.1	6.4	9.4	15
340 HE/RE	4	1020	8.9	4.4	11.1	15	1020	8.9	6.4	11.6	15
370 HE/RE	5	1020	8.9	5.5	11.1	15	1020	8.9	8	11.6	15

FLA = Full Load Amps MCA = Minimum Circuit Ampacity MOP = Maximum Over Current Protection

\* Electrical wiring is to be sized in accordance with minimum circuit ampacity

**Hot Gas Defrost Models - 208-230/1/60**

Model TLV	No. of Fans	Standard PSC Motor					Optional EC Motor				
		Drain Pan Heater Watts	Heater Amps	Fan Motor FLA	MCA*	MOP	Drain Pan Heater Watts	Heater Amps	Fan Motor FLA	MCA*	MOP
060 HE/RE	1	580	2.5	0.5	3.2	15	580	2.5	0.5	2.9	15
090 HE/RE	1	580	2.5	0.5	3.2	15	580	2.5	1.0	2.9	15
120 HE/RE	2	580	2.5	1.0	3.2	15	580	2.5	1.0	2.9	15
150 HE/RE	2	580	2.5	1.0	3.2	15	580	2.5	2.0	2.9	15
180 HE/RE	3	820	3.6	1.5	4.5	15	820	3.6	1.5	4.1	15
220 HE/RE	3	820	3.6	1.5	4.5	15	820	3.6	3.0	4.1	15
270 HE/RE	3	820	3.6	1.5	4.5	15	820	3.6	3.0	4.1	15
300 HE/RE	4	820	3.6	2.0	4.5	15	820	3.6	4.0	4.1	15
340 HE/RE	4	1020	4.4	2.0	5.5	15	1020	4.4	4.0	5.1	15
370 HE/RE	5	1020	4.4	2.5	5.5	15	1020	4.4	5.0	5.1	15

FLA = Full Load Amps MCA = Minimum Circuit Ampacity MOP = Maximum Over Current Protection

\* Electrical wiring is to be sized in accordance with minimum circuit ampacity

- NOTES: 1) Dimensions shown in inches & (mm). These are typical for Air, Electric and Hot gas defrost models.  
 2) Electrical connection end is opposite to the piping end on all models.  
 3) 1/4" (6 mm) O.D. external equalizer line and service access fitting included on all suction headers inside end compartment

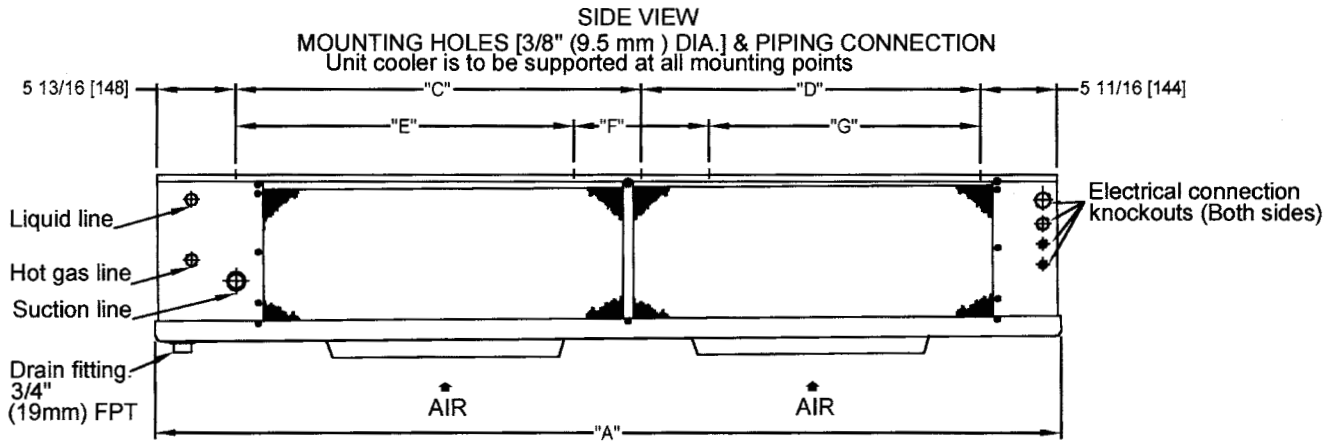
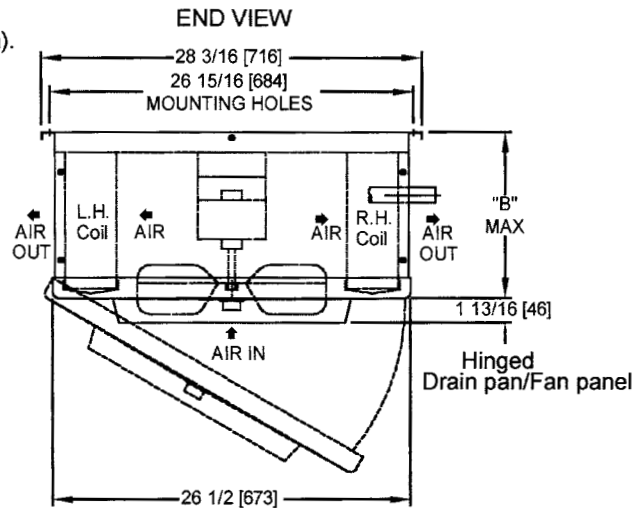

MODEL TLV	No. of Fans	DIMENSIONAL DATA - INCHES (mm)									
		Suction Connection (OD)	Distributor Inlet (OD)	Hot Gas Side Conn. (OD)	A	B	Mounting Holes				
							C	D	E	F	G
060	1	5/8 (16)	1/2 (13)	1/2 (13)	66 7/8 (1699)	8 11/16 (221)	27 1/2 (699)	27 1/2 (699)	-	-	-
090	1	7/8 (22)	1/2 (13)	1/2 (13)	66 7/8 (1699)	9 9/16 (252)	27 1/2 (699)	27 1/2 (699)	-	-	-
120	2	7/8 (22)	1/2 (13)	1/2 (13)	66 7/8 (1699)	12 7/16 (316)	27 1/2 (699)	27 1/2 (699)	-	-	-
150	2	1 1/8 (29)	1/2 (13)	1/2 (13)	66 7/8 (1699)	14 15/16 (378)	27 1/2 (699)	27 1/2 (699)	-	-	-
180	3	1 1/8 (29)	1/2 (13)	1/2 (13)	92 7/8 (2359)	14 15/16 (378)	40 1/2 (1029)	40 1/2 (1029)	-	-	-
220	3	1 1/8 (29)	1/2 (13)	1/2 (13)	92 7/8 (2359)	14 15/16 (378)	40 1/2 (1029)	40 1/2 (1029)	-	-	-
270	3	1 1/8 (29)	* 7/8 (22)	5/8 (16)	92 7/8 (2359)	17 7/16 (443)	40 1/2 (1029)	40 1/2 (1029)	-	-	-
300	4	1 1/8 (29)	* 7/8 (22)	5/8 (16)	92 7/8 (2359)	17 7/16 (443)	40 1/2 (1029)	40 1/2 (1029)	-	-	-
340	4	1 3/8 (35)	* 7/8 (22)	5/8 (16)	112 7/8 (2867)	17 7/16 (443)	-	-	40 1/2 (1029)	20 (508)	40 1/2 (1029)
370	5	1 3/8 (35)	* 7/8 (22)	5/8 (16)	112 7/8 (2867)	17 7/16 (443)	-	-	40 1/2 (1029)	20 (508)	40 1/2 (1029)

\* Reducer supplied to accommodate 1/2" or 7/8" TXV outlet connection.

# RECOMMENDED INSTALLATION CLEARANCES

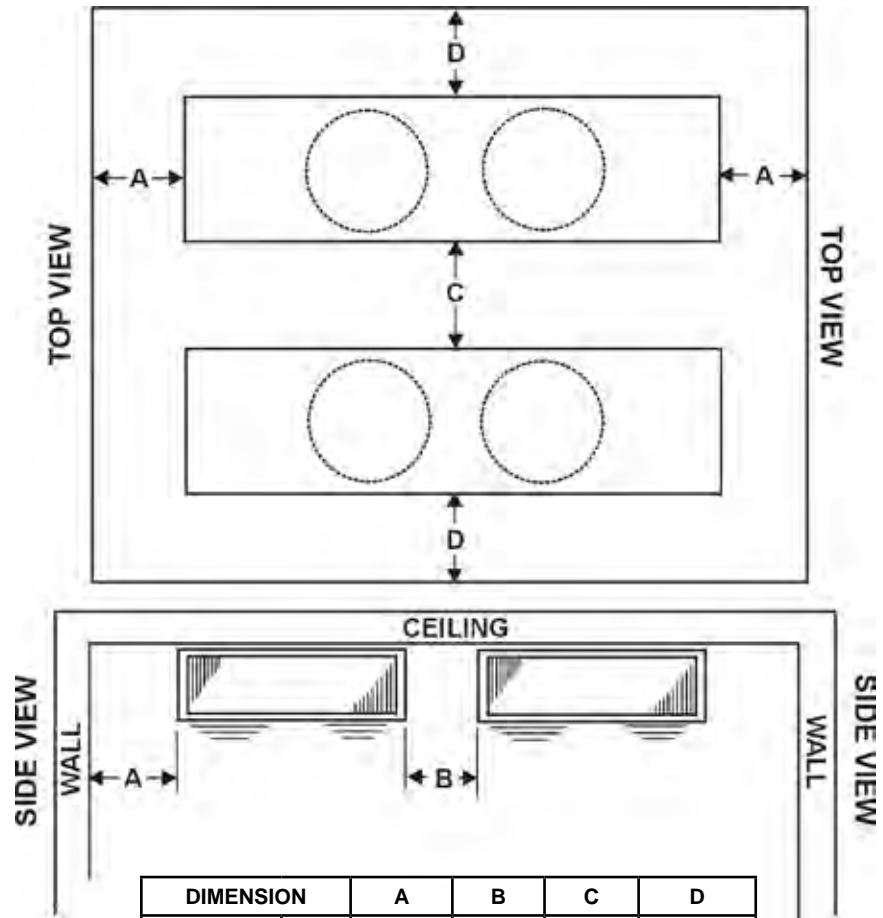

DIMENSION		A	B	C	D
Minimum	ft.	2	2	6	3
	(cm.)	(61)	(61)	(183)	(92)
Maximum	ft.	-	7	40	20
	(cm.)	-	(210)	(1200)	(600)

# WIRING DIAGRAM

## AIR DEFROST - 120V & 208-230V

### AIR DEFROST

**TYPICAL WIRING:** FOR MULTIPLE EVAPORATORS AND OTHER ALTERNATIVE WIRING, SEE INSTALLATION MANUAL

#### WITH DEFROST TIME CLOCK

#### WITHOUT DEFROST TIME CLOCK

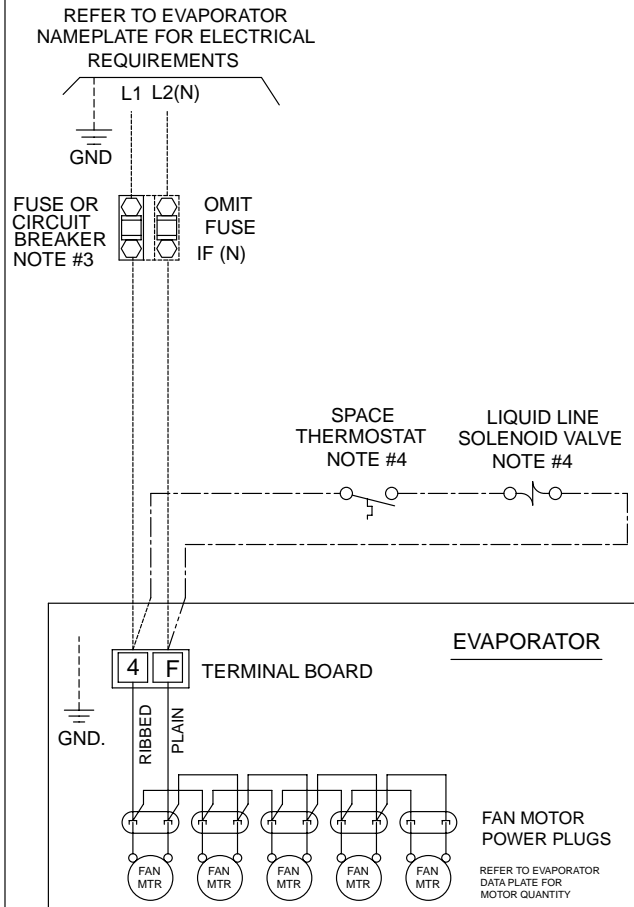
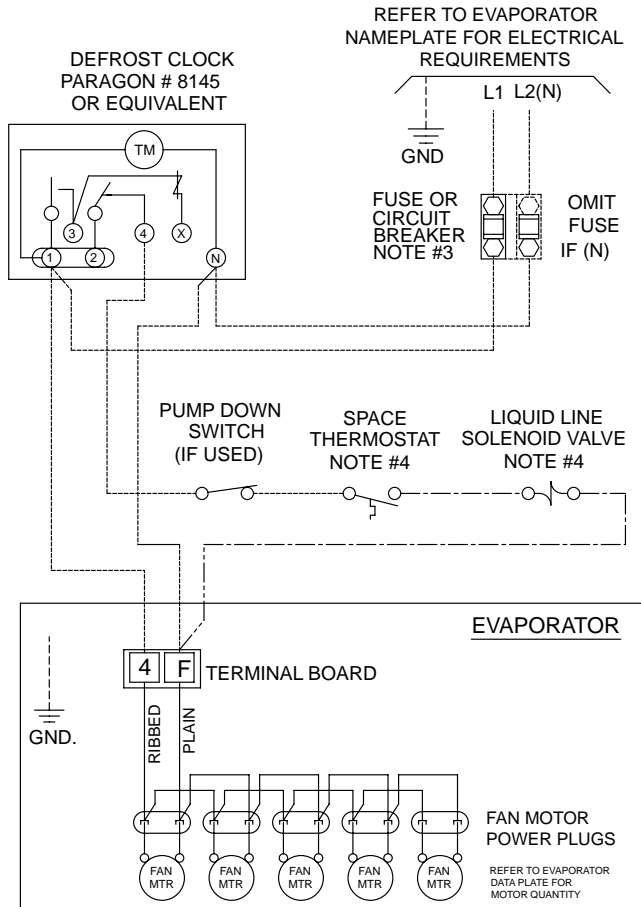

#### NOTES

- 1). USE COPPER CONDUCTORS ONLY
- 2). USE 75°C WIRE (OR HIGHER)
- 3). OVERCURRENT PROTECTION FOR EVAPORATOR FAN MOTORS AND DEFROST HEATERS MUST NOT EXCEED MAXIMUM VALUE SHOWN ON EVAPORATOR NAMEPLATE.
- 4). MAY BE FACTORY INSTALLED-MOUNTED AND WIRED ON EVAPORATOR (PRE-ASSEMBLED MODELS)

#### TERMINALS

- DH - DRAIN PAN HEATER
- - COMPONENT TERMINAL - MARKED
- ◊ - COMPONENT TERMINAL - UNMARKED (IDENTIFIABLE BY LOCATION)
- - COMPONENT TERMINAL - UNMARKED (UNIDENTIFIABLE)
- - TERMINAL BLOCK TERMINAL
- - WIRE SPLICE

#### CONDUCTORS/WIRING

- FACTORY WIRING
- WIRING BY OTHERS
- OPTIONAL FACTORY OR BY OTHERS

ALL FIELD WIRING MUST BE DONE IN COMPLIANCE WITH ALL APPLICABLE LOCAL AND NATIONAL CODES.

REV A  
11/05/01  
1073979



## AIR DEFROST - 460V

TYPICAL WIRING: FOR MULTIPLE EVAPORATORS AND OTHER ALTERNATIVE WIRING, SEE INSTALLATION MANUAL

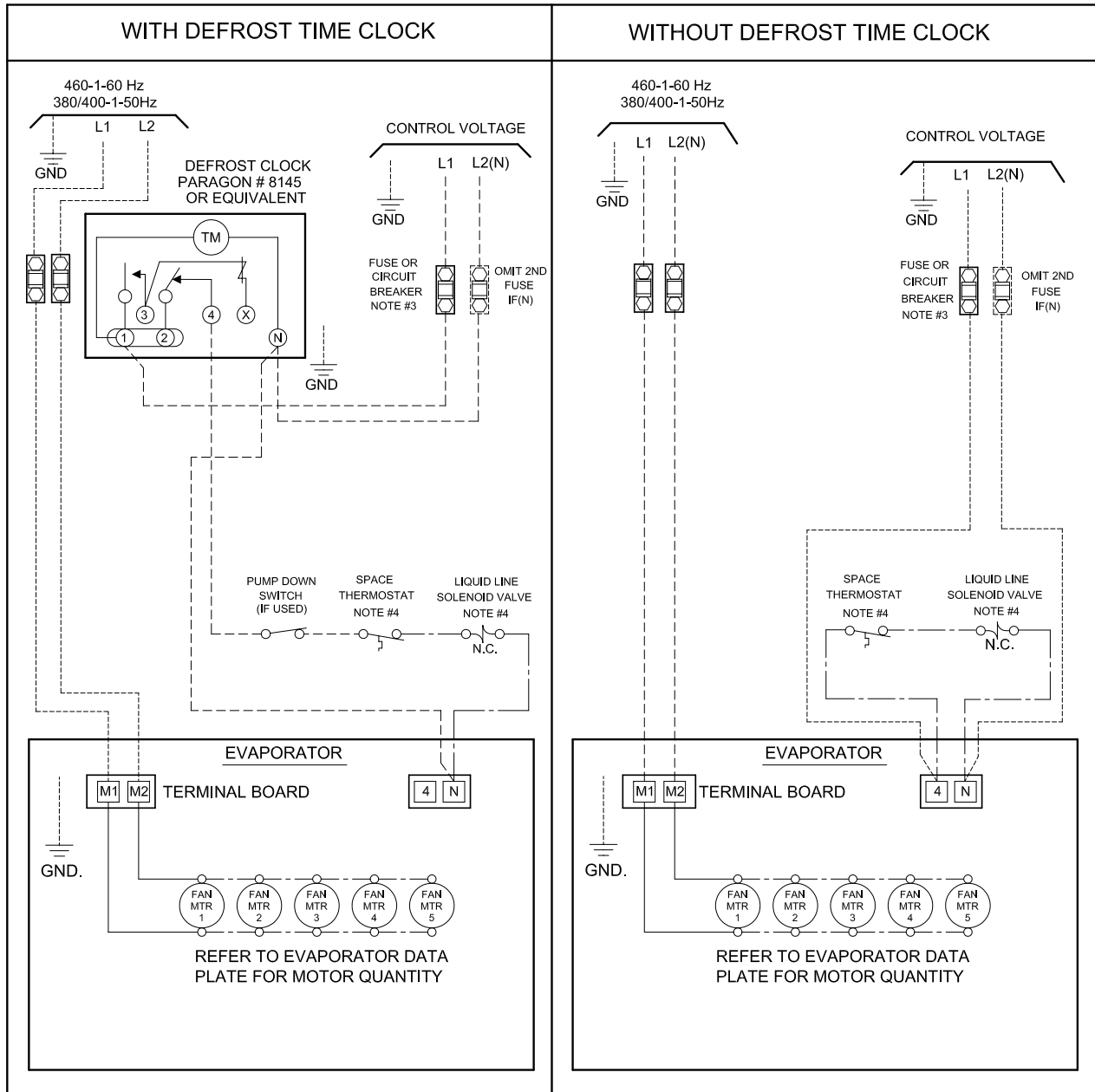

**NOTES**

- 1). USE COPPER CONDUCTORS ONLY
- 2). USE 90°C WIRE (OR HIGHER)
- 3). OVERCURRENT PROTECTION FOR EVAPORATOR FAN MOTORS MUST NOT EXCEED MAXIMUM VALUE SHOWN ON EVAPORATOR NAMEPLATE.
- 4). MAY BE FACTORY INSTALLED-MOUNTED AND WIRED ON EVAPORATOR .
- 5). REFER TO EVAPORATOR DATA PLATE FOR MOTOR QUANTITY

KTM AD 06/16

**TERMINALS**

- -COMPONENT TERMINAL
- -TERMINAL BLOCK TERMINAL

**CONDUCTORS/WIRING**

- FACTORY WIRING
- - - - - WIRING BY OTHERS
- OPTIONAL FACTORY OR BY OTHERS

ALL FIELD WIRING MUST BE DONE IN COMPLIANCE WITH ALL APPLICABLE LOCAL AND NATIONAL CODES.

# WIRING DIAGRAM

## ELECTRIC DEFROST - SINGLE EVAPORATOR

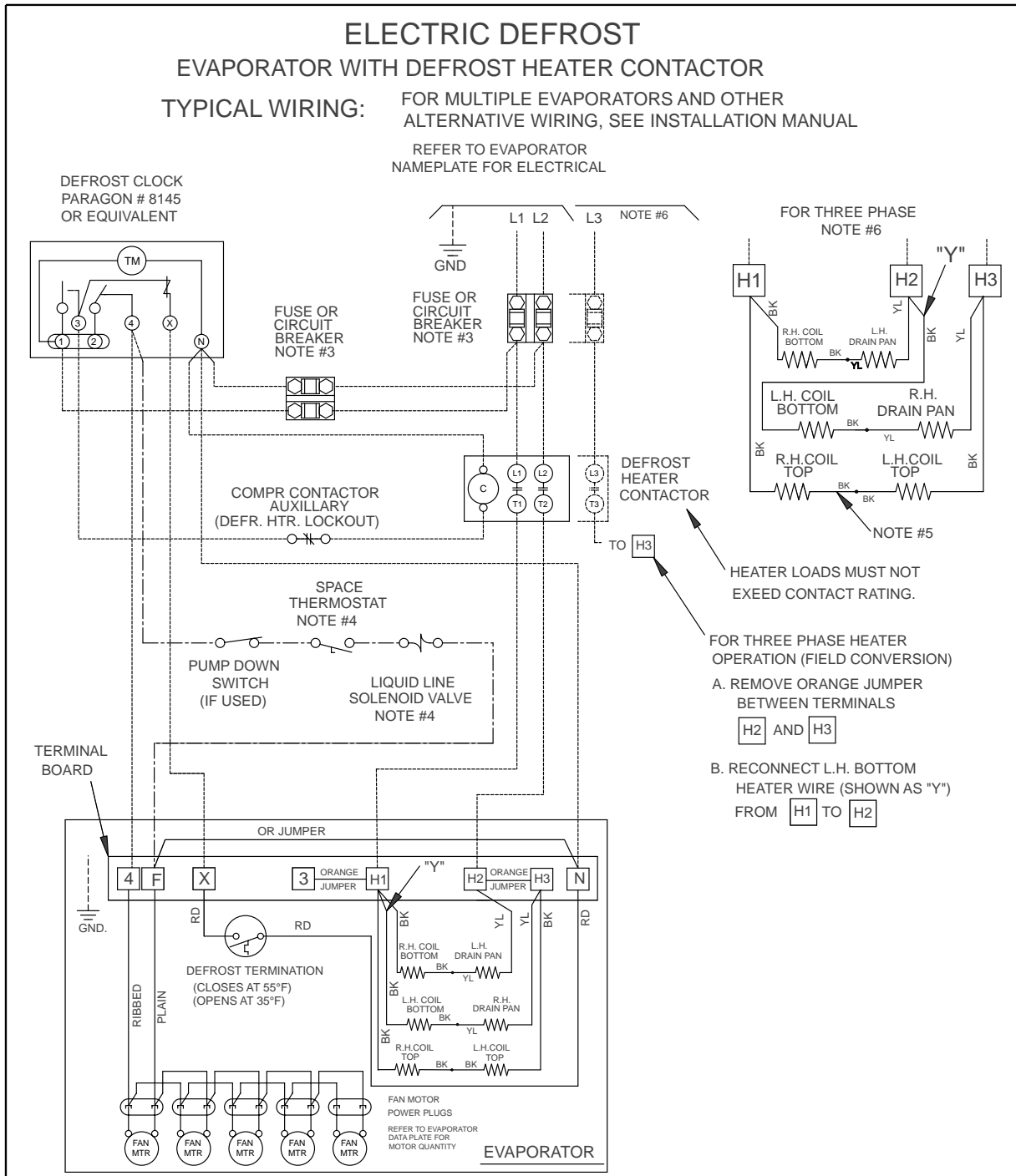

**NOTES**

- 1). USE COPPER CONDUCTORS ONLY
- 2). USE 75°C WIRE (OR HIGHER)
- 3). OVERCURRENT PROTECTION FOR EVAPORATOR FAN MOTORS AND DEFROST HEATERS MUST NOT EXCEED MAXIMUM VALUE SHOWN ON EVAPORATOR NAMEPLATE.
- 4). MAY BE FACTORY INSTALLED-MOUNTED AND WIRED ON EVAPORATOR (PRE-ASSEMBLED MODELS) ON MULTIPLE PRE-ASSEMBLED EVAPORATORS WIRE SECOND EVAPORATOR SOLENOID IN PARALLEL WITH FIRST ONE. ONLY USE ONE THERMOSTAT.
- 5). THESE HEATERS NOT USED ON \_LV060ED AND \_LV090ED MODELS

**TERMINALS**

- - COMPONENT TERMINAL - MARKED
- - COMPONENT TERMINAL - UNMARKED (IDENTIFIABLE BY LOCATION)
- - COMPONENT TERMINAL - UNMARKED (UNIDENTIFIABLE)
- - TERMINAL BLOCK TERMINAL
- - WIRE SPLICE

**CONDUCTORS/WIRING**

- FACTORY WIRING
- WIRING BY OTHERS
- OPTIONAL FACTORY OR BY OTHERS

ALL FIELD WIRING MUST BE DONE IN COMPLIANCE WITH ALL APPLICABLE LOCAL AND NATIONAL CODES.

REV B  
11/05/01  
1073978

ELECTRIC DEFROST - MULTIPLE EVAPORATORS

FOR ALL MODELS USING DEFROST HEATER CONTACTOR

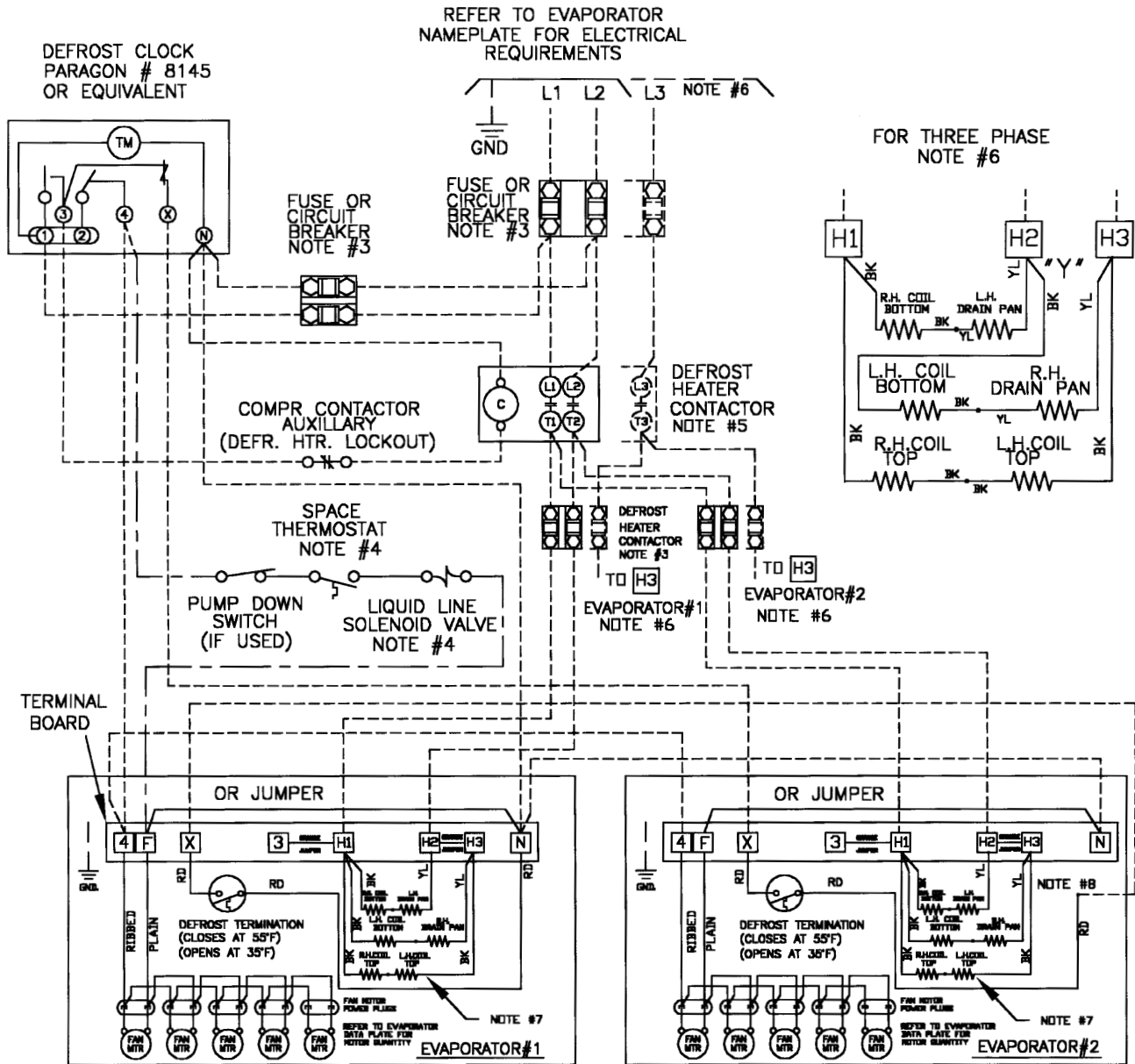

NOTES		TERMINALS
<p>1). USE COPPER CONDUCTORS ONLY</p> <p>2). USE 60°C WIRE (OR HIGHER)</p> <p>3). OVERCURRENT PROTECTION FOR EVAPORATOR FAN MOTORS AND DEFROST HEATERS MUST NOT EXCEED MAXIMUM VALUE SHOWN ON EVAPORATOR NAMEPLATE.</p> <p>4). MAY BE FACTORY INSTALLED-MOUNTED AND WIRED ON EVAPORATOR (PRE-ASSEMBLED MODELS) ON MULTIPLE PRE-ASSEMBLED EVAPORATORS WIRE SECOND EVAPORATOR SOLENOID IN PARALLEL WITH FIRST ONE. ONLY USE ONE THERMOSTAT.</p>	<p>5). HEATER LOADS MUST NOT EXCEED CONTACT RATING.</p> <p>6). FOR THREE PHASE HEATER OPERATION (FIELD CONVERSION)</p> <p>A. REMOVE ORANGE JUMPER BETWEEN TERMINALS <b>H2</b> AND <b>H3</b></p> <p>B. RECONNECT L.H. BOTTOM HEATER WIRE (SHOWN AS "Y") FROM <b>H1</b> TO <b>H2</b></p> <p>7). TOP HEATERS NOT USED ON MODELS <b>_LV060ED</b> &amp; <b>_LV090ED</b></p> <p>8). REMOVE RD WIRE FROM TERMINAL AND SPLICE AS SHOWN <b>N</b></p>	<p>○ - COMPONENT TERMINAL - MARKED</p> <p>○ - COMPONENT TERMINAL - UNMARKED (&lt; IDENTIFIABLE BY LOCATION &gt;)</p> <p>○ - COMPONENT TERMINAL - UNMARKED (&lt; UNIDENTIFIABLE &gt;)</p> <p>□ - TERMINAL BLOCK TERMINAL</p> <p>• - WIRE SPLICE</p> <p><b>CONDUCTORS/WIRING</b></p> <p>————— FACTORY WIRING</p> <p>----- WIRING BY OTHERS</p> <p>----- OPTIONAL FACTORY WIRING OR BY OTHERS</p> <p>ALL FIELD WIRING MUST BE DONE IN COMPLIANCE WITH ALL APPLICABLE LOCAL AND NATIONAL CODES.</p>

**ELECTRIC DEFROST - (For optional use on models 060ED and 090ED operating on 208-230/1/60)**

**ELECTRIC DEFROST**

**EVAPORATOR WITHOUT DEFROST HEATER CONTACTOR USING MAX 15A HEATER OVERCURRENT PROTECTION**

**TYPICAL WIRING: FOR MULTIPLE EVAPORATORS AND OTHER ALTERNATIVE WIRING, SEE INSTALLATION MANUAL**

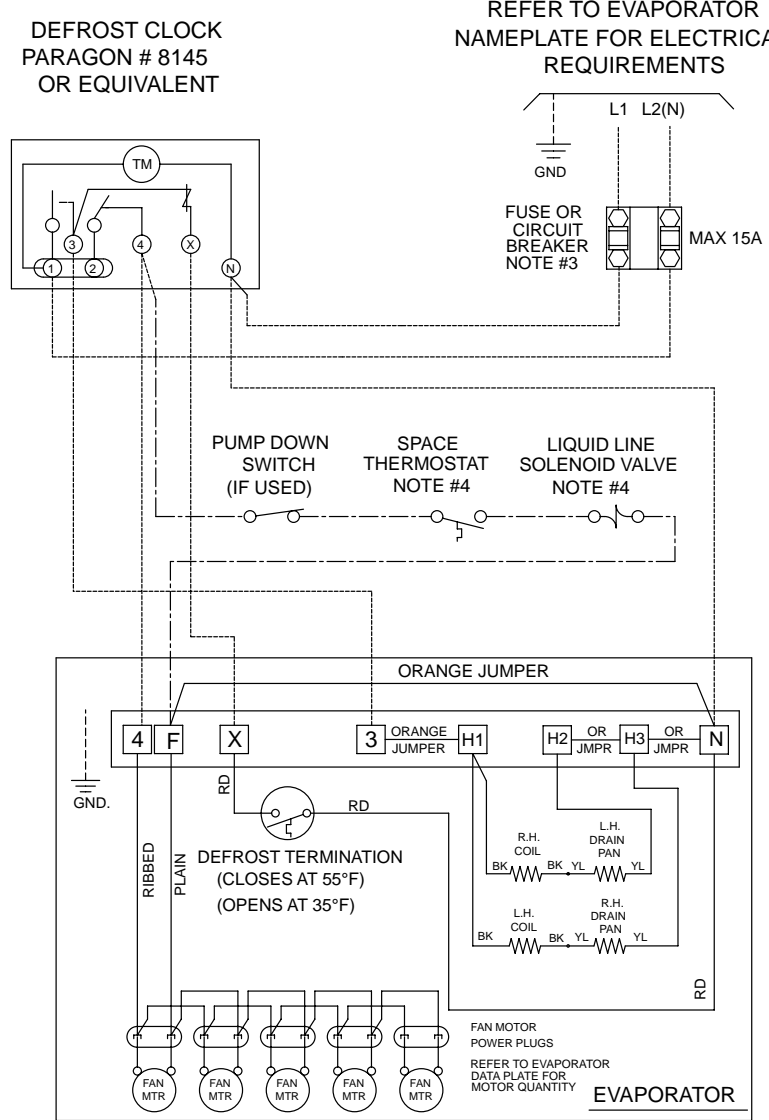

**NOTES**

- 1). USE COPPER CONDUCTORS ONLY
- 2). USE 75°C WIRE (OR HIGHER)
- 3). OVERCURRENT PROTECTION FOR EVAPORATOR FAN MOTORS AND DEFROST HEATERS MUST NOT EXCEED MAXIMUM VALUE SHOWN ON EVAPORATOR NAMEPLATE.
- 4). MAY BE FACTORY INSTALLED-MOUNTED AND WIRED ON EVAPORATOR (PRE-ASSEMBLED MODELS) ON MULTIPLE PRE-ASSEMBLED EVAPORATORS WIRE SECOND EVAPORATOR SOLENOID IN PARALLEL WITH FIRST ONE. ONLY USE ONE THERMOSTAT.

**TERMINALS**

- - COMPONENT TERMINAL - MARKED
- - COMPONENT TERMINAL - UNMARKED (IDENTIFIABLE BY LOCATION)
- - COMPONENT TERMINAL - UNMARKED (UNIDENTIFIABLE)
- - TERMINAL BLOCK TERMINAL
- - WIRE SPLICE

**CONDUCTORS/WIRING**

- FACTORY WIRING
- WIRING BY OTHERS
- - - - - OPTIONAL FACTORY OR BY OTHERS

ALL FIELD WIRING MUST BE DONE IN COMPLIANCE WITH ALL APPLICABLE LOCAL AND NATIONAL CODES.

1074180  
REV-A

HOT GAS DEFROST - 120V & 208-230V

REVERSE CYCLE AND 3-PIPE HOT GAS DEFROST

REFER TO EVAPORATOR NAMEPLATE FOR ELECTRICAL REQUIREMENTS

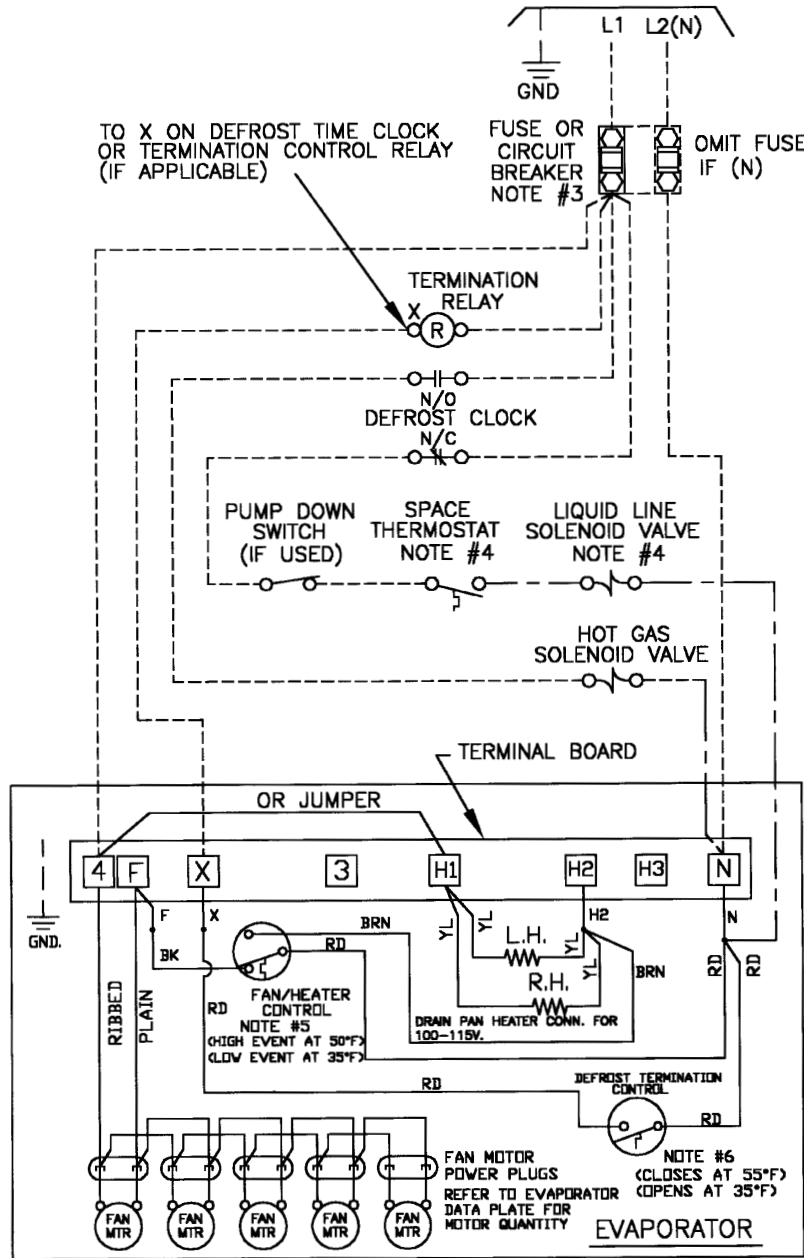

\*FOR 3-PIPE SEE NOTES #5 & 6

DRAIN PAN HEATER CONN. FOR 200-230V

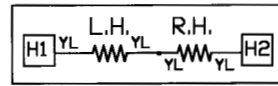

NOTES

- 1). USE COPPER CONDUCTORS ONLY
- 2). USE 60°C WIRE (OR HIGHER)
- 3). OVERCURRENT PROTECTION FOR EVAPORATOR FAN MOTORS AND DEFROST HEATERS MUST NOT EXCEED MAXIMUM VALUE SHOWN ON EVAPORATOR NAMEPLATE.
- 4). MAY BE FACTORY INSTALLED-MOUNTED AND WIRED ON EVAPORATOR (PRE-ASSEMBLED MODELS).
- 5). FAN/HEATER CONTROL IS INSTALLED ON THE SUCTION LINE LOCATION FOR REVERSE CYCLE AND MUST BE MOVED TO THE DISTRIBUTOR SIDE PORT LOCATION FOR 3-PIPE HOT GAS DEFROST.
- 6). DEFROST TERMINATION CONTROL IS INSTALLED AT THE DISTRIBUTOR SIDE PORT LOCATION FOR REVERSE CYCLE AND MUST BE MOVED TO THE SUCTION LINE LOCATION FOR 3-PIPE HOT GAS DEFROST.

TERMINALS

- DH - DRAIN PAN HEATER
- - COMPONENT TERMINAL - MARKED
- - COMPONENT TERMINAL - UNMARKED ( IDENTIFIABLE BY LOCATION )
- - COMPONENT TERMINAL - UNMARKED ( UNIDENTIFIABLE )
- - TERMINAL BLOCK TERMINAL
- - WIRE SPLICE

CONDUCTORS/WIRING

- FACTORY WIRING
- WIRING BY OTHERS
- OPTIONAL FACTORY OR BY OTHERS

ALL FIELD WIRING MUST BE DONE IN COMPLIANCE WITH ALL APPLICABLE LOCAL AND NATIONAL CODES.

REV 11/09/01

NOTE: DURING THE HOT GAS DEFROST CYCLE, THE FAN/HEATER CONTROL DE-ENERGIZES THE EVAPORATOR FANS AND ENERGIZES THE DRAIN PAN HEATERS, ANYTIME TEMPERATURE OF INCOMING REFRIGERANT GAS IS ABOVE 50°F

US Patents  
8,635,883 &  
9,151,525

## DESIGN FEATURES



- Standard on all EC Motors
- NO special controls required.
- Refrigeration mode – EC motor operates at full speed.  
Consumption 95 W per motor
- Off Cycle mode – EC motor operates at reduced speed.  
Consumption 25 W per motor.
- Energy saving benefit on motor and compressor wattage consumption:

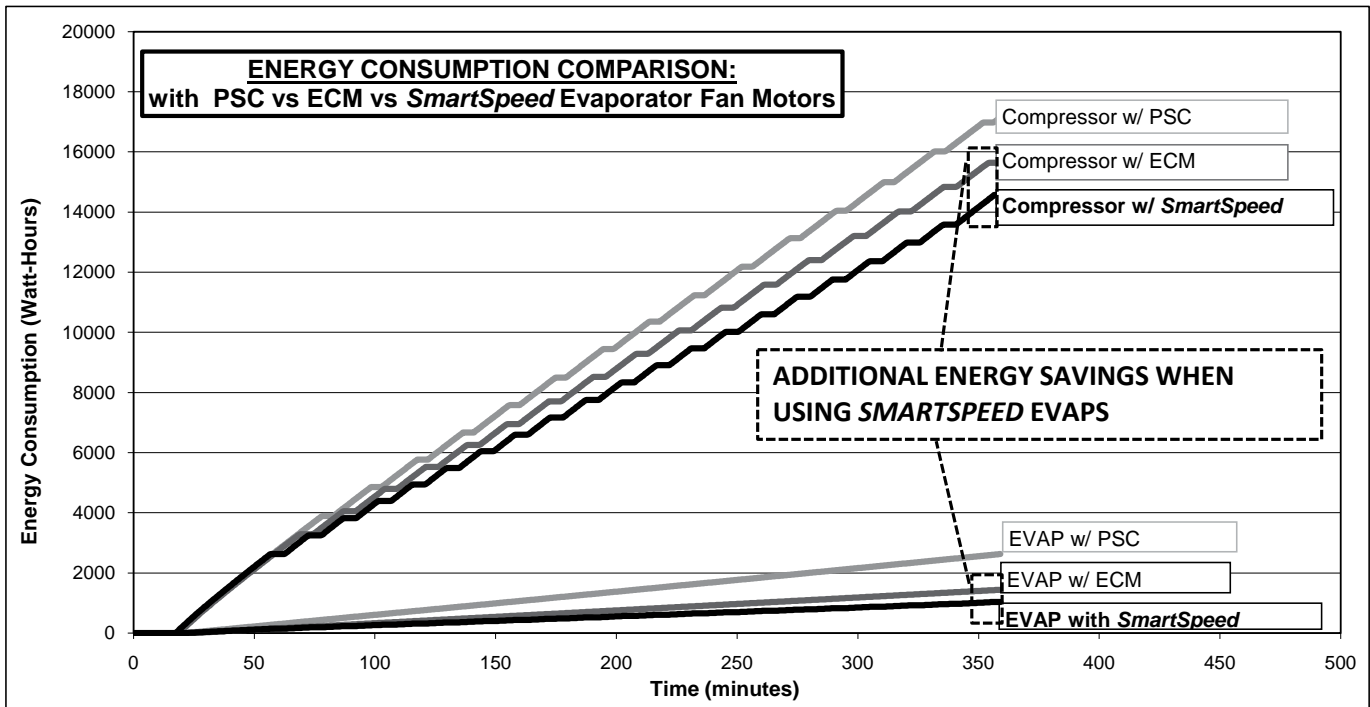

Note: Data collected on a typical freezer application with a 3HP low temp condensing unit and a 4 fan TLP evaporator. Similar results can be expected with TLV evaporators.

## INSTALLATION NOTES

EC motors are factory wired for SmartSpeed operation on evaporators equipped **with** a factory installed thermostat.

For SmartSpeed operation on Evaporators **without** a factory installed thermostat, a field wired SPDT type thermostat is required.

# WIRING DIAGRAM - 120V & 208-230V OPTIONAL EC MOTOR with SMARTSPEED™ AIR DEFROST MODELS

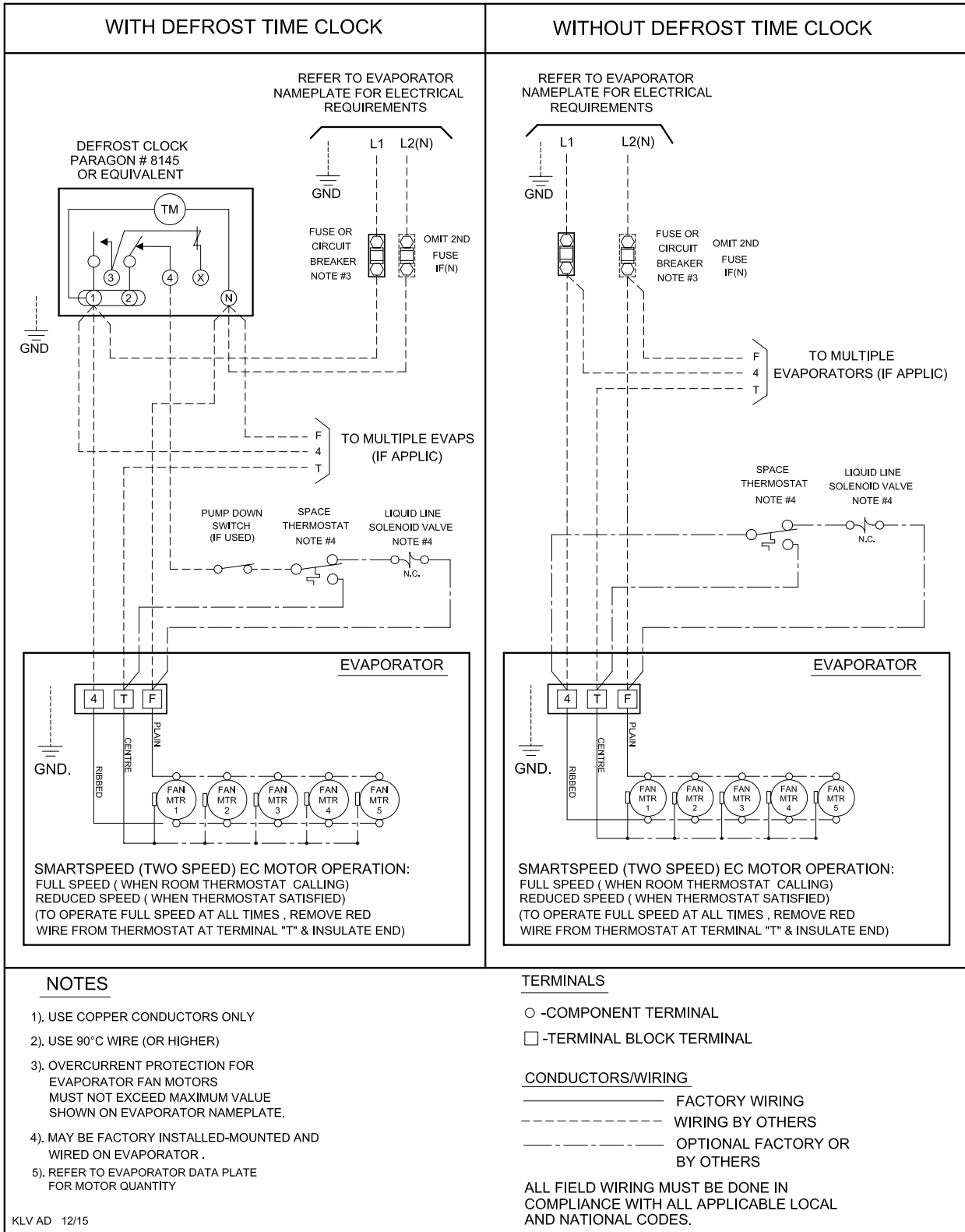

# WIRING DIAGRAM - 208-230/1/60 OPTIONAL EC MOTOR with SMARTSPEED™ ELECTRIC DEFROST MODELS 060ED AND 090ED

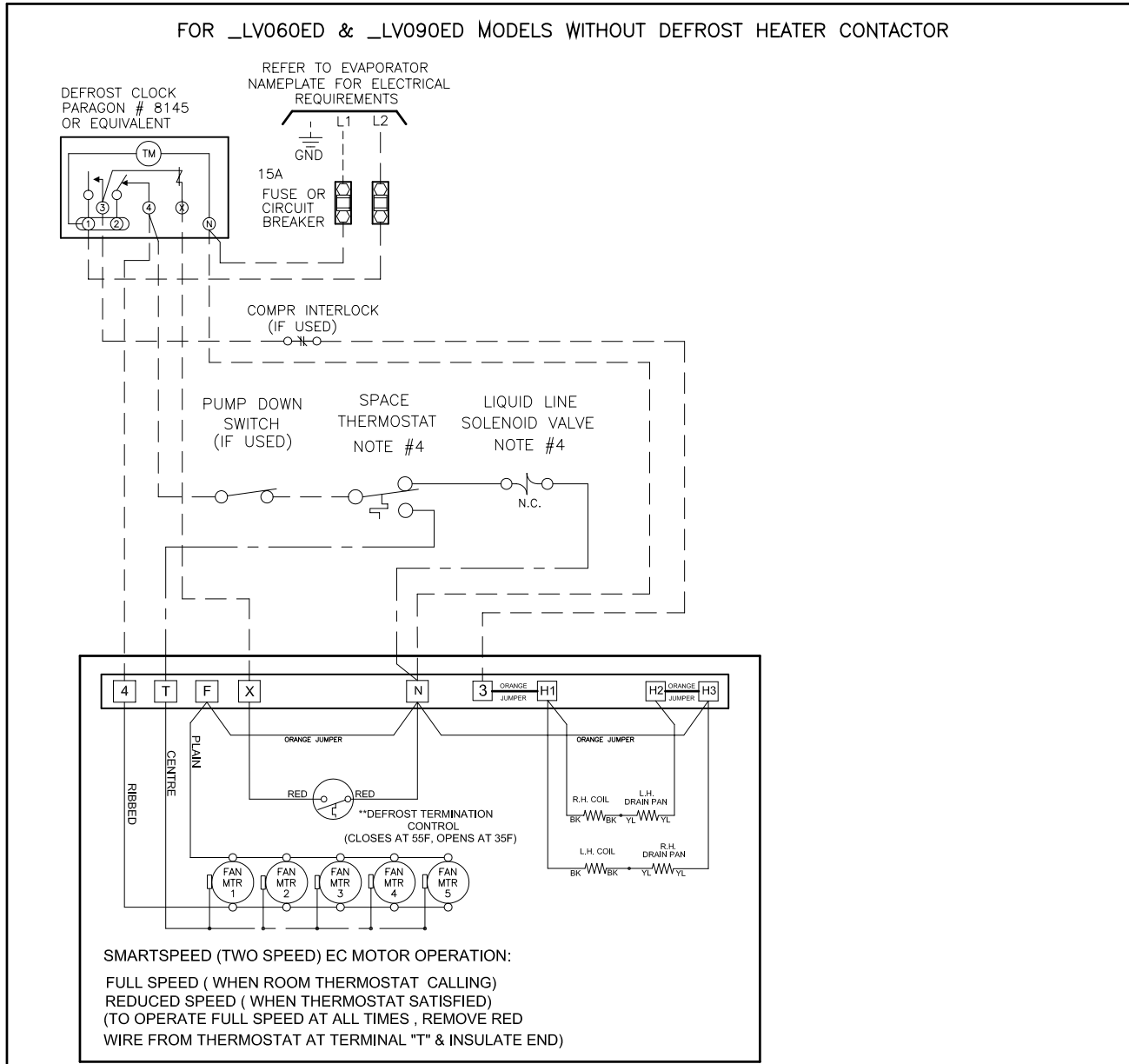

## NOTES

- 1). USE COPPER CONDUCTORS ONLY
- 2). USE 90°C WIRE (OR HIGHER)
- 3). OVERCURRENT PROTECTION FOR EVAPORATOR FAN MOTORS AND DEFROST HEATERS MUST NOT EXCEED MAXIMUM VALUE SHOWN ON EVAPORATOR NAMEPLATE.
- 4). MAY BE FACTORY INSTALLED-MOUNTED AND WIRED ON EVAPORATOR
- 5). REFER TO EVAPORATOR DATA PLATE FOR MOTOR QUANTITY

## TERMINALS

- -COMPONENT TERMINAL
- -TERMINAL BLOCK TERMINAL

## CONDUCTORS/WIRING

- FACTORY WIRING
- - - - - WIRING BY OTHERS
- OPTIONAL FACTORY OR BY OTHERS

ALL FIELD WIRING MUST BE DONE IN COMPLIANCE WITH ALL APPLICABLE LOCAL AND NATIONAL CODES.



# WIRING DIAGRAM - 208-230/1/60 OPTIONAL EC MOTOR with SMARTSPEED™ ELECTRIC DEFROST MODELS 120ED TO 370ED

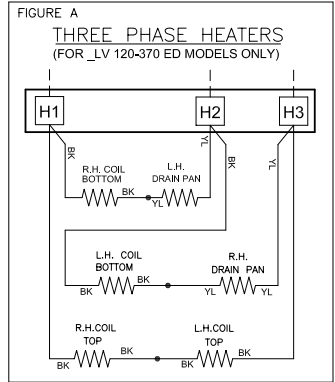
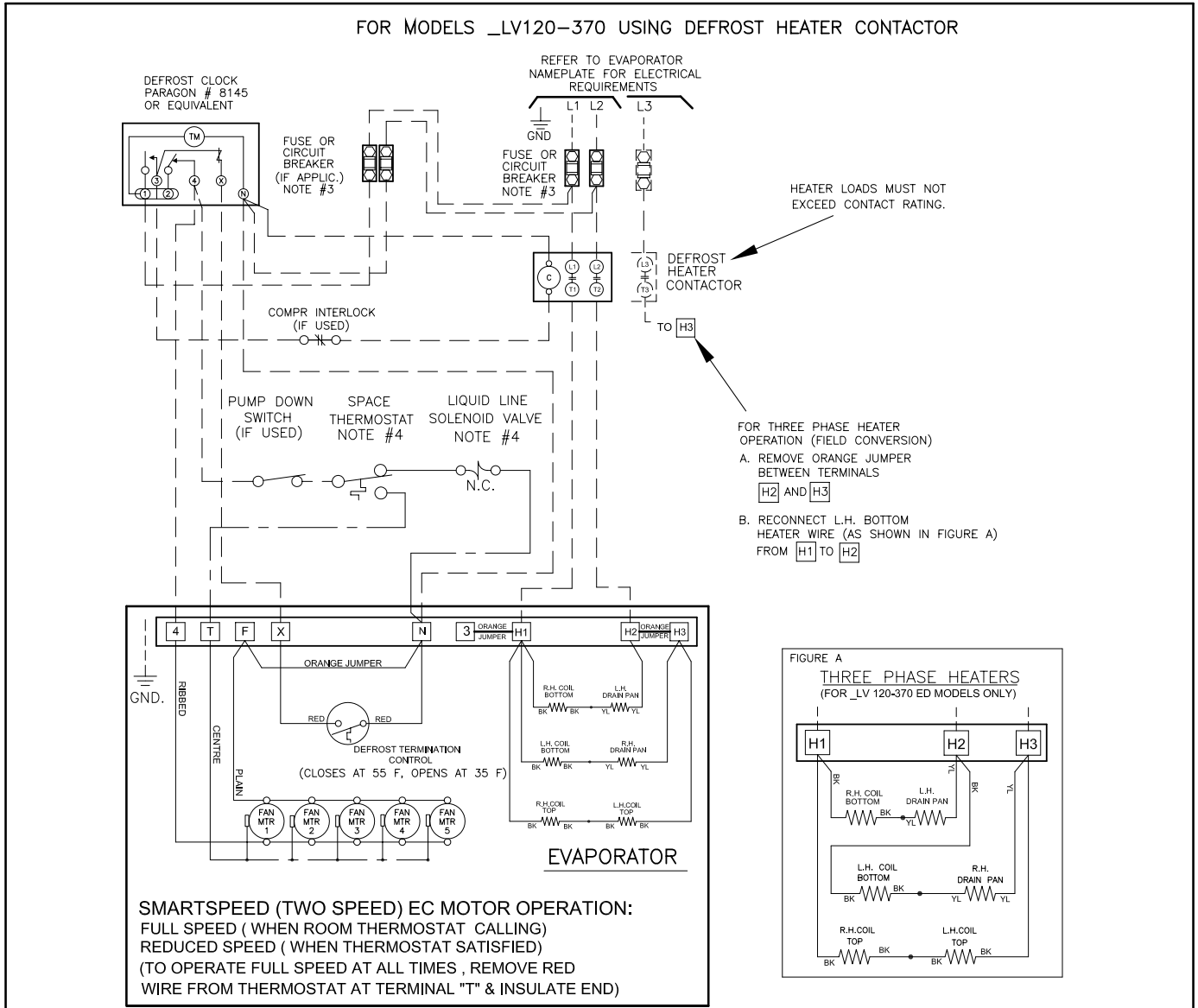

**NOTES**

- 1). USE COPPER CONDUCTORS ONLY
- 2). USE 90°C WIRE (OR HIGHER)
- 3). OVERCURRENT PROTECTION FOR EVAPORATOR FAN MOTORS AND DEFROST HEATERS MUST NOT EXCEED MAXIMUM VALUE SHOWN ON EVAPORATOR NAMEPLATE.
- 4). MAY BE FACTORY INSTALLED-MOUNTED AND WIRED ON EVAPORATOR
- 5). REFER TO EVAPORATOR DATA PLATE FOR MOTOR QUANTITY

**TERMINALS**

- -COMPONENT TERMINAL
- -TERMINAL BLOCK TERMINAL

**CONDUCTORS/WIRING**

- FACTORY WIRING
- - - - - WIRING BY OTHERS
- · - · - · - OPTIONAL FACTORY OR BY OTHERS

ALL FIELD WIRING MUST BE DONE IN COMPLIANCE WITH ALL APPLICABLE LOCAL AND NATIONAL CODES.

# WIRING DIAGRAM - 208-230/1/60 OPTIONAL EC MOTOR with SMARTSPEED™ ELECTRIC DEFROST MODELS - MULTIPLE EVAPORATORS

FOR ALL MODELS USING DEFROST HEATER CONTACTOR

REFER TO EVAPORATOR NAMEPLATE FOR ELECTRICAL REQUIREMENTS

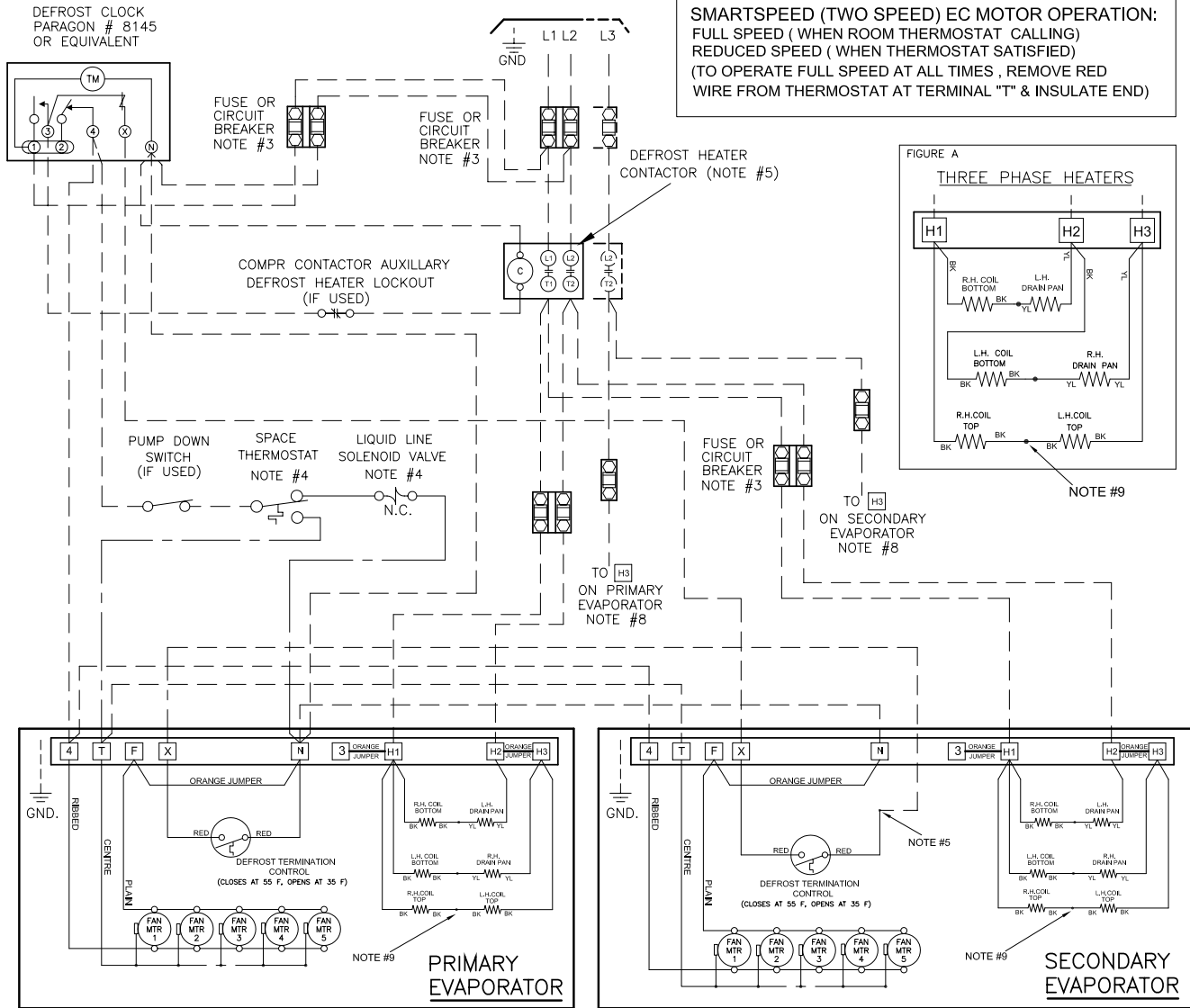

**SMARTSPEED (TWO SPEED) EC MOTOR OPERATION:**  
FULL SPEED ( WHEN ROOM THERMOSTAT CALLING )  
REDUCED SPEED ( WHEN THERMOSTAT SATISFIED )  
( TO OPERATE FULL SPEED AT ALL TIMES , REMOVE RED  
WIRE FROM THERMOSTAT AT TERMINAL "T" & INSULATE END )

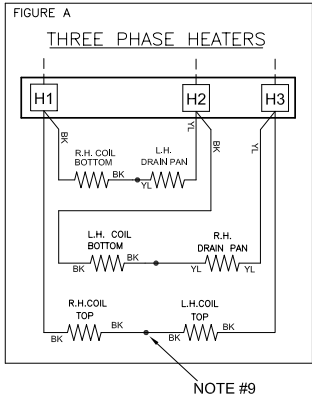

**NOTES**

- 1). USE COPPER CONDUCTORS ONLY
- 2). USE 90°C WIRE (OR HIGHER)
- 3). OVERCURRENT PROTECTION FOR EVAPORATOR FAN MOTORS AND DEFROST HEATERS MUST NOT EXCEED MAXIMUM VALUE SHOWN ON EVAPORATOR NAMEPLATE
- 4). MAY BE FACTORY INSTALLED-MOUNTED AND WIRED ON EVAPORATOR. (PRE-ASSEMBLED MODELS) ON MULTIPLE PRE-ASSEMBLED EVAPORATORS, WIRE SECOND EVAPORATOR SOLENOID IN PARALLEL WITH FIRST. USE ONLY ONE THERMOSTAT.
- 5). REMOVE RED WIRE FROM TERMINAL [N] AND SPLICE AS SHOWN
- 6). HEATER LOADS MUST NOT EXCEED CONTACTOR RATING
- 7). REFER TO EVAPORATOR DATA PLATE FOR MOTOR QUANTITY
- 8). FOR FIELD CONVERSION TO THREE PHASE HEATERS:
  - 8a). REMOVE ORANGE JUMPER BETWEEN TERMINALS [H2] AND [H3]
  - 8b). RECONNECT LH BOTTOM COIL WIRE FROM [H1] TO [H2]. AS SHOWN IN FIGURE A
- 9). TOP HEATER COILS ARE NOT INSTALLED ON \_LV060ED & \_LV090ED MODELS.

**TERMINALS**

- -COMPONENT TERMINAL
- -TERMINAL BLOCK TERMINAL

**CONDUCTORS/WIRING**

- FACTORY WIRING
- - - - - WIRING BY OTHERS
- OPTIONAL FACTORY OR BY OTHERS

ALL FIELD WIRING MUST BE DONE IN COMPLIANCE WITH ALL APPLICABLE LOCAL AND NATIONAL CODES.

# INTUITIVE EVAPORATOR CONTROL TECHNOLOGY

## What is ESP+?

Trenton Refrigeration's ESP+ intuitive evaporator control technology is designed to replace traditional electro-mechanical refrigeration controls typically used on medium and low temperature applications. By combining award winning adaptive technology along with an electronic expansion valve, Trenton Refrigeration continues Leading The Way with innovative, state-of-the-art designs.

Installing an evaporator utilizing the ESP+ intuitive evaporator control technology is simple. Two pipes, two wires and you're done. No interconnecting control wiring between the evaporator and the condensing unit is required.

- Quick simple installation
- Improved evaporator performance by minimizing excessive frost on the evaporator
  - Eliminates ice build up on surfaces and product
  - Energy savings through evaporator fan management
  - Energy savings with reduction in the number of defrost cycles
    - Defrost heater management
- Improved system diagnostics and service through advanced alarm notification text/email
  - Remote monitoring & system control
    - User friendly interface
  - Precise temperature control for prolonged product shelf life
  - Improved product integrity with less potential for spoilage
  - Downloadable data provides system history for prior 30 days
- Remotely view and change system parameters and alarm settings
  - Manually control system
  - Easily troubleshoot issues

### ESP+ controls:

- Box Temperature     - Superheat
- Defrost Initiation     - Defrost Termination     - Fan Motors
- Defrost Heater (Electric Defrost Models)

*Plus - User can access operating data directly from the system interface*

**15-20% System Energy Savings  
over a Properly Commissioned System!**

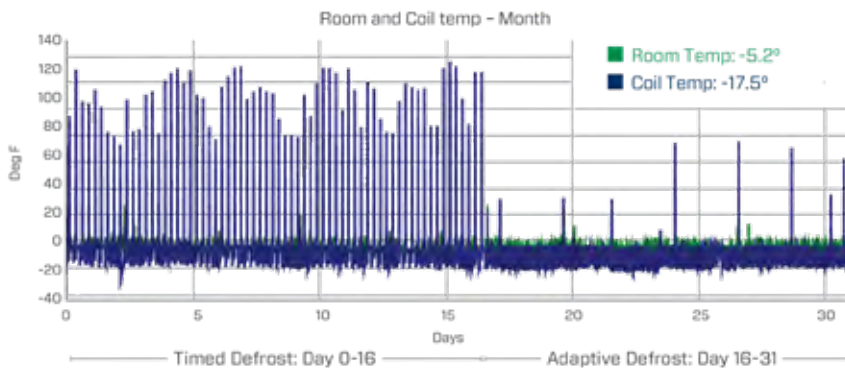

### 86% Fewer Defrost Cycles\*

- Enhanced system performance
- Energy Savings
- Improved product integrity

\* Data may vary depending on application

**Visit [www.t-rp.com/esp](http://www.t-rp.com/esp) for details**

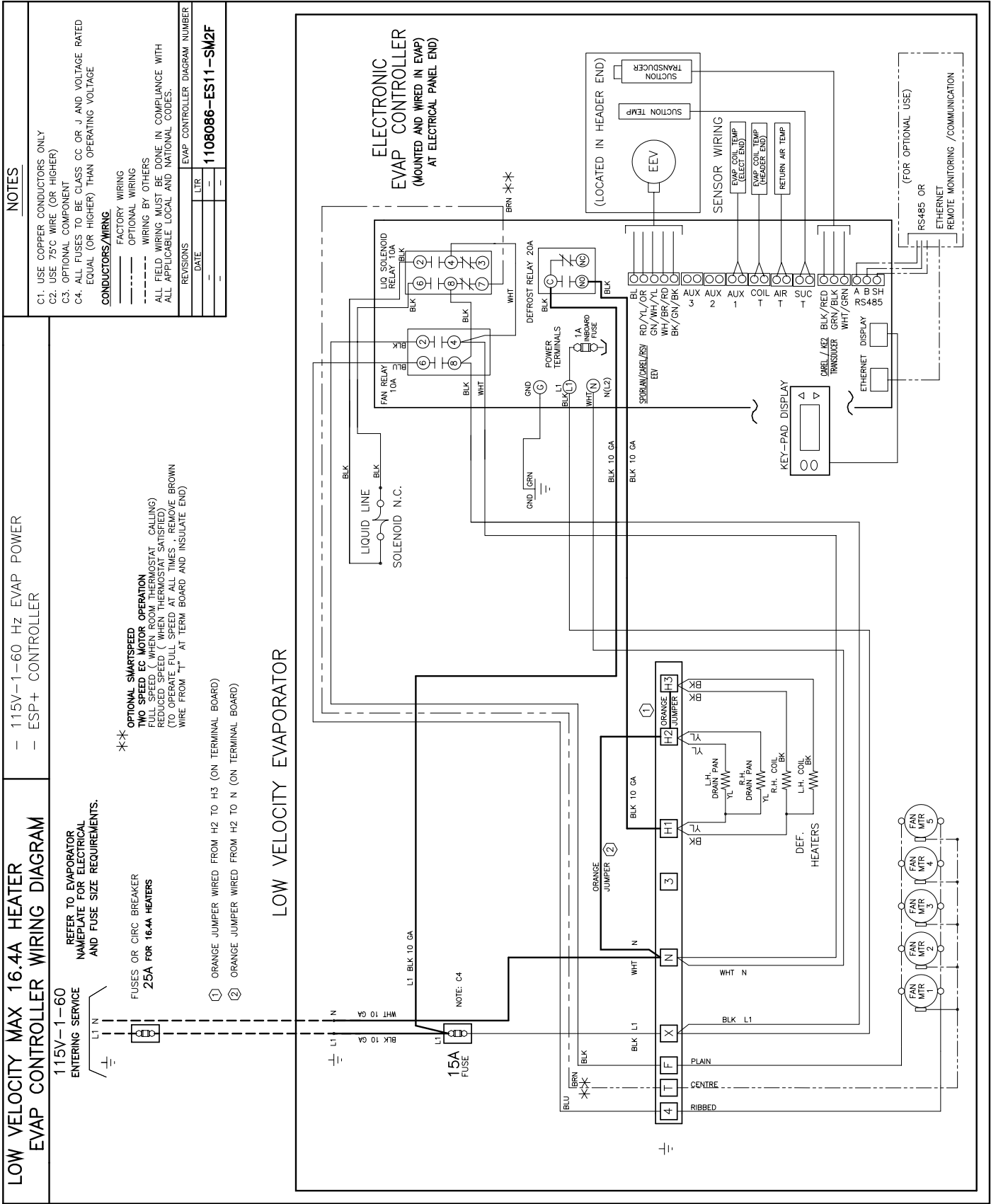

# WIRING DIAGRAM - 230/1/60

## ELECTRIC DEFROST - MAX. 12A HEATER

### MODELS w/ **ESP**

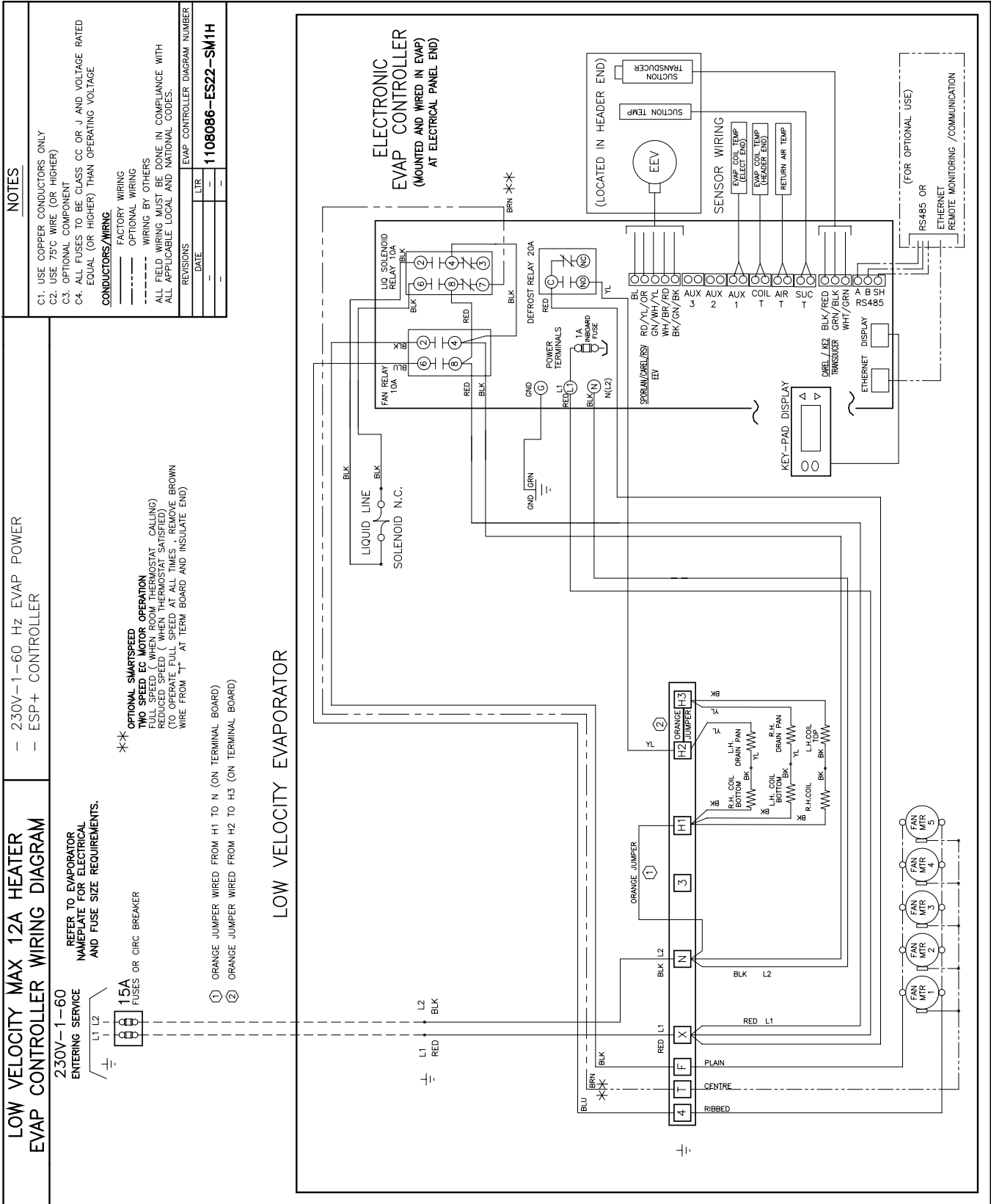

# WIRING DIAGRAM - 230/1/60

## ELECTRIC DEFROST - MAX. 25A HEATER

### MODELS w/ **ESP+**

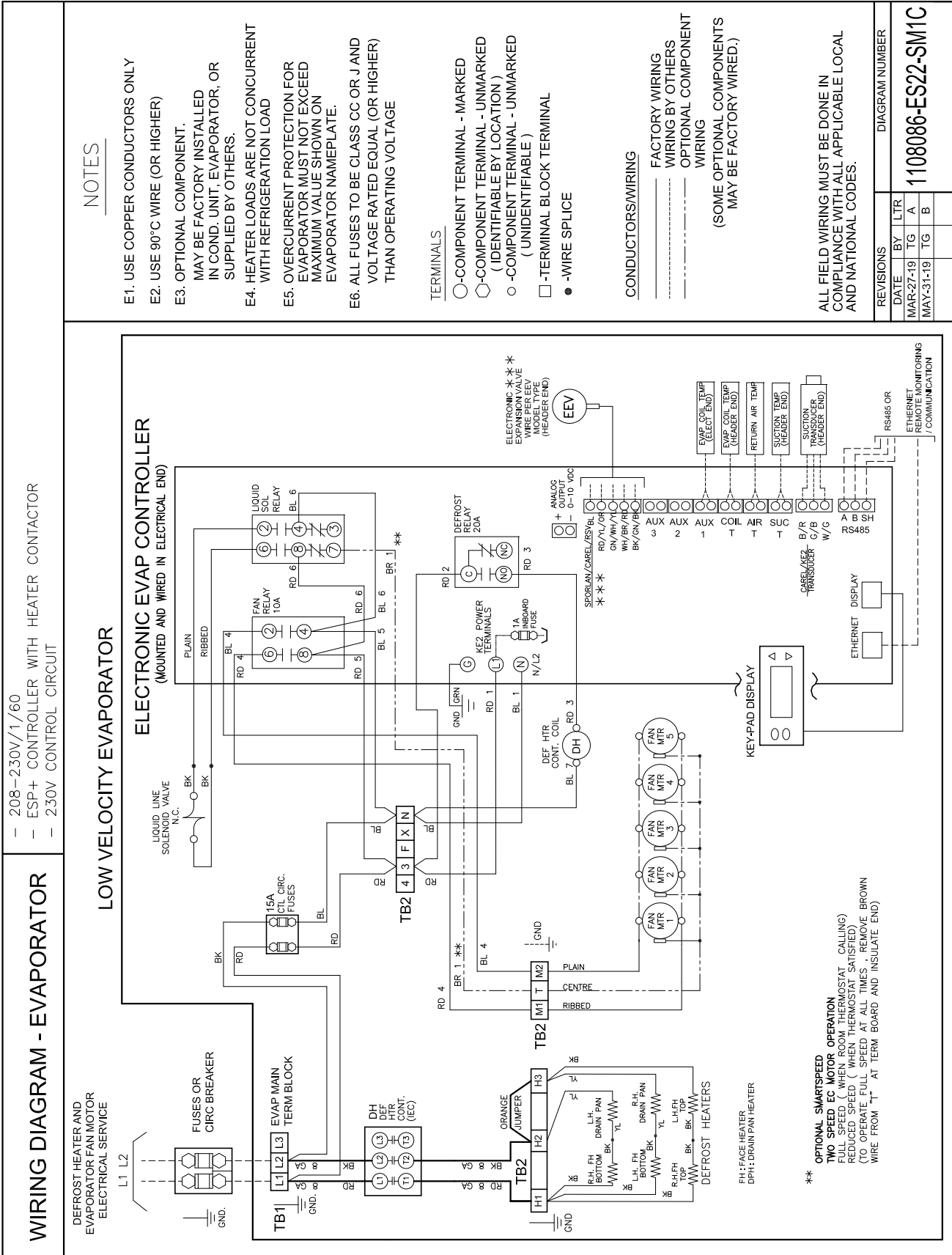

### NOTES

E1. USE COPPER CONDUCTORS ONLY  
 E2. USE 90°C WIRE (OR HIGHER)  
 E3. OPTIONAL COMPONENT. MAY BE FACTORY INSTALLED IN COND. UNIT, EVAPORATOR, OR SUPPLIED BY OTHERS.  
 E4. HEATER LOADS ARE NOT CONCURRENT WITH REFRIGERATION LOAD  
 E5. OVERCURRENT PROTECTION FOR EVAPORATOR MUST NOT EXCEED MAXIMUM VALUE SHOWN ON EVAPORATOR NAMEPLATE.  
 E6. ALL FUSES TO BE CLASS CC OR J AND VOLTAGE RATED EQUAL (OR HIGHER) THAN OPERATING VOLTAGE

### TERMINALS

○ -COMPONENT TERMINAL - MARKED  
 ○ -COMPONENT TERMINAL - UNMARKED (IDENTIFIABLE BY LOCATION)  
 ○ -COMPONENT TERMINAL - UNMARKED (UNIDENTIFIABLE)  
 □ -TERMINAL BLOCK TERMINAL  
 ● -WIRE SPLICE

### CONDUCTORS/WIRING

— FACTORY WIRING  
 - - - WIRING BY OTHERS  
 - - - OPTIONAL COMPONENT WIRING  
 (SOME OPTIONAL COMPONENTS MAY BE FACTORY WIRED.)

ALL FIELD WIRING MUST BE DONE IN COMPLIANCE WITH ALL APPLICABLE LOCAL AND NATIONAL CODES.

REVISIONS		DIAGRAM NUMBER	
DATE	BY	LTR	
MAR-27-19	TG	A	<b>1108086-ES22-SM1C</b>
MAY-31-19	TG	B	

# WIRING DIAGRAM - 230/1/60

## ELECTRIC DEFROST - MAX. 14A TO 20A HEATER

### MODELS w/ **ESP**

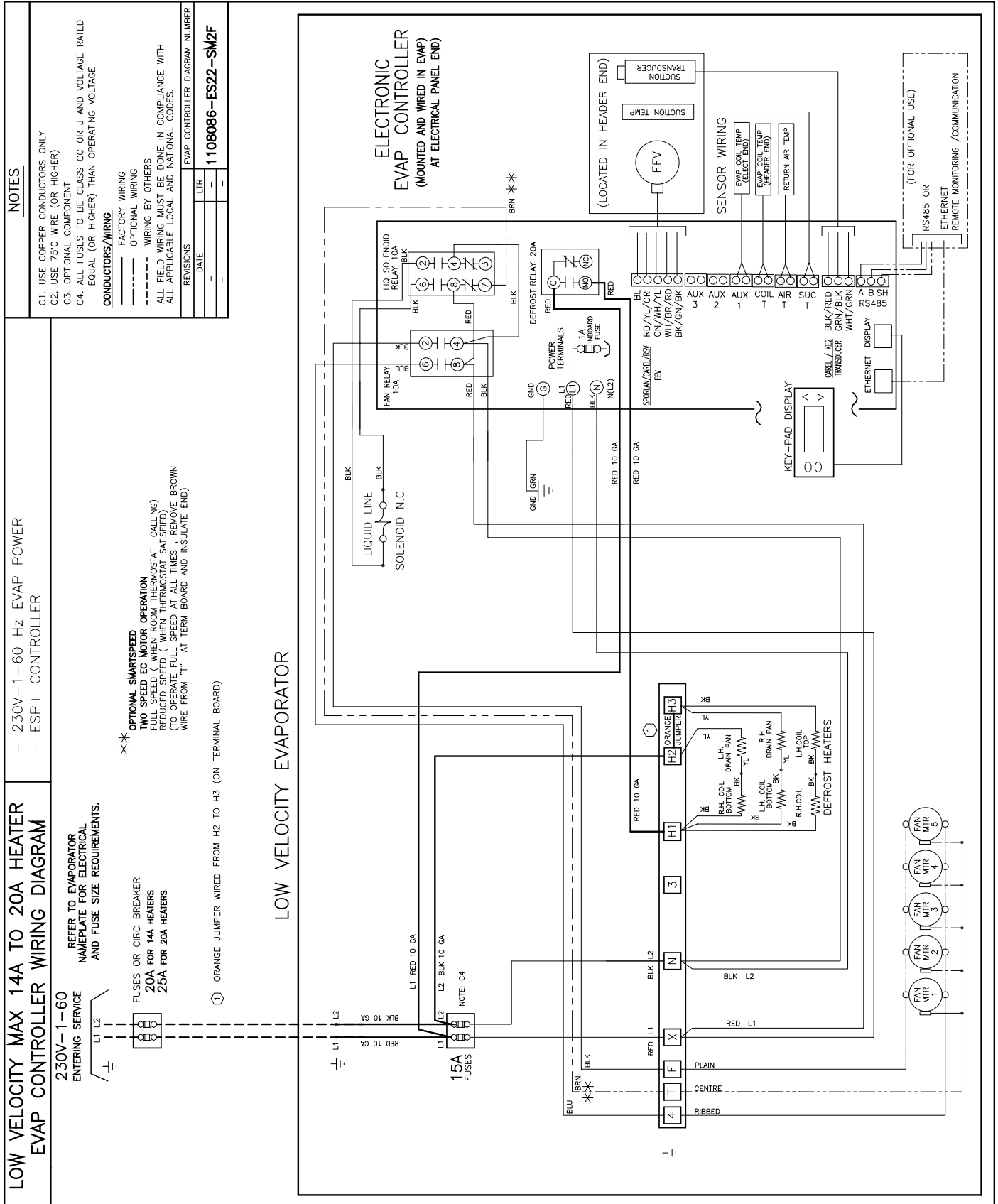

# THERMOSTATIC EXPANSION VALVE SELECTION - SPORLAN

MODEL TLV	TD °F	R448A R407A R407C R22	R404A R507 *
060	10	SBFVE-AA-VC	SBFSE-AA-SC
	15	SBFVE-AA-VC	SBFSE-A-SC
090	10	SBFVE-AA-VC	SBFSE-A-SC
	15	SBFVE-A-VC	SBFSE-B-SC
120	10	SBFVE-A-VC	SBFSE-A-SC
	15	SBFVE-A-VC	SBFSE-B-SC
150	10	SBFVE-A-VC	SBFSE-B-SC
	15	SBFVE-B-VC	SBFSE-B-SC
180	10	SBFVE-A-VC	SBFSE-B-SC
	15	SBFVE-B-VC	SBFSE-C-SC
220	10	SBFVE-B-VC	SBFSE-B-SC
	15	SBFVE-B-VC	SBFSE-C-SC
270	10	SBFVE-B-VC	SBFSE-C-SC
	15	SBFVE-C-VC	SSE-4-C
300	10	SBFVE-B-VC	SSE-3-C
	15	SBFVE-C-VC	SSE-4-C
340	10	SBFVE-B-VC	SSE-3-C
	15	SVE-4-C	SSE-4-C
370	10	SVE-4-C	SSE-4-C
	15	SVE-4-C	SSE-6-C

SELECTIONS BASED ON 100°F(37.7°C) LIQUID

\* FOR R507 REPLACE "S" WITH "P"

For R449A, use R448A data.

## DISTRIBUTOR NOZZLE SELECTION

STANDARD NOZZLES FACTORY INSTALLED FOR ALL MODELS	
T.D.	8°F TO 12°F (4.4°C to 6.6°C)
EVAP. TEMP. RANGE	18°F TO 40°F (-7.7°C TO 4.4°C)
REFRIGERANT	R404A R507 R448A R407A R407C R22
060	L-3/4
090	L- 1
120, 150	L-1 1/2
180	L- 2
220	L-2 1/2
270	G- 2 1/2
300	G- 3
340, 370	G-4

SELECTIONS BASED ON 100 °F(37.7 °C) LIQUID

For R449A, use R448A data.



**FACTORY INSTALLED  
EXPANSION VALVE SELECTIONS -  
MODELS w/ **ESP+****

**MEDIUM TEMPERATURE  
R448A R407A  
AIR OR ELECTRIC DEFROST**

MODEL TLV	FACTORY INSTALLED NOZZLE	FACTORY INSTALLED EXPANSION VALVE	FACTORY INSTALLED LIQUID LINE SOLENOID VALVE
060	L3/4	E2V9	3
090	L1	E2V9	3
120	L1-1/2	E2V11	3
150	L1-1/2	E2V11	3
180	L2	E2V14	3
220	L2-1/2	E2V14	5
270	G2-1/2	E2V18	5
300	G3	E2V18	5
340	G4	E2V18	5
370	G4	E2V24	6

\*\*\* Insert defrost type. See nomenclature for details

**MEDIUM TEMPERATURE  
R404A R507  
AIR OR ELECTRIC DEFROST**

MODEL TLV	FACTORY INSTALLED NOZZLE	FACTORY INSTALLED EXPANSION VALVE	FACTORY INSTALLED LIQUID LINE SOLENOID VALVE
060	L3/4	E2V11	3
090	L1	E2V14	3
120	L1-1/2	E2V14	3
150	L1-1/2	E2V18	5
180	L2	E2V24	5
220	L2-1/2	E2V24	5
270	G2-1/2	E2V24	6
300	G3	E2V24	6
340	G4	E2V24	6
370	G4	E2V35	6

\*\*\* Insert defrost type. See nomenclature for details

	<p>Visit <b><a href="http://www.t-rp.com/esp">www.t-rp.com/esp</a></b> for Quick Start Guide, Operation Manual, etc</p>
---	---

**FAN/HEATER CONTROL AND DEFROST TERMINATION CONTROL POSITION**

1. DEFROST TERMINATION CONTROL THERMOSTAT LOCATION FOR REVERSE CYCLE HOT GAS DEFROST
2. FAN/HEATER CONTROL THERMOSTAT MUST BE REINSTALLED HERE FOR 3-PIPE(BYPASS) HOT GAS DEFROST

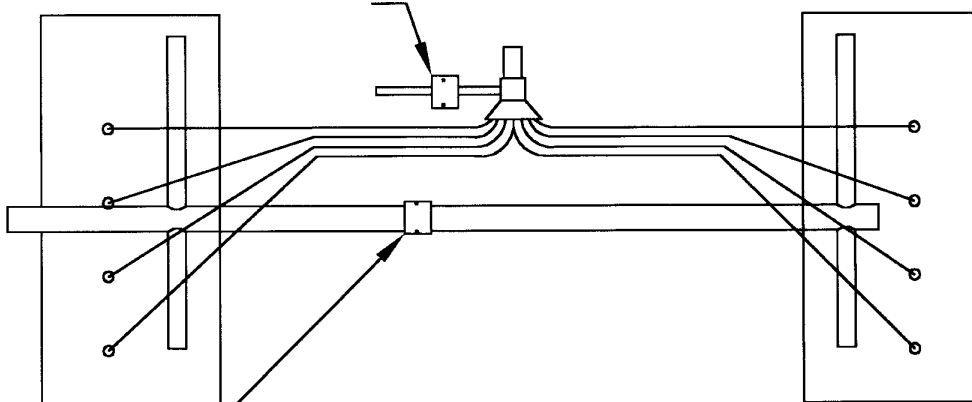

1. FAN/HEATER CONTROL THERMOSTAT LOCATION FOR REVERSE CYCLE HOT GAS DEFROST
2. DEFROST TERMINATION CONTROL THERMOSTAT MUST BE REINSTALLED HERE FOR 3-PIPE(BYPASS) HOT GAS DEFROST

FIGURE 1

UNIT COOLER WILL LEAVE THE FACTORY WITH THE FAN/HEATER AND DEFROST TERMINATION CONTROL THERMOSTAT INSTALLED IN THE REVERSE CYCLE POSITION\*

**HOT GAS DEFROST (REVERSE CYCLE)**

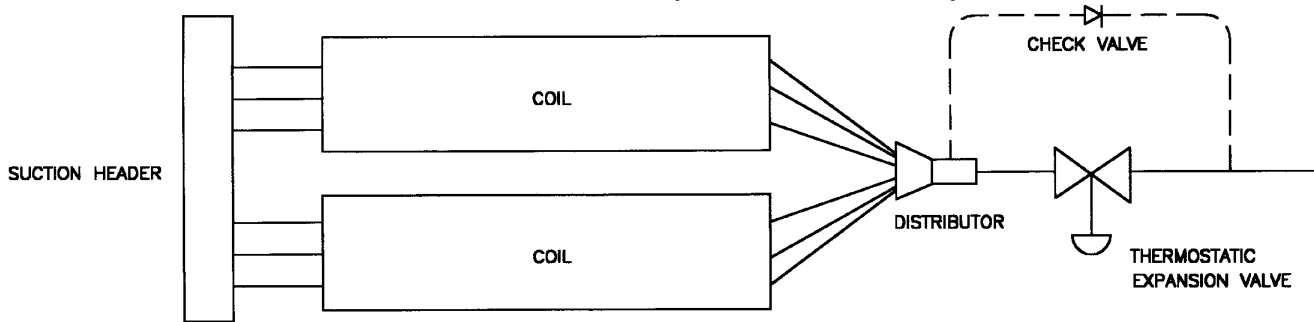

FIGURE 2

UNIT COOLER SHOWING HOT GAS LINE AND CHECK VALVE AROUND EXPANSION VALVE AS USED FOR REVERSE CYCLE HOT GAS DEFROST

**HOT GAS DEFROST (3-PIPE OR BYPASS)**

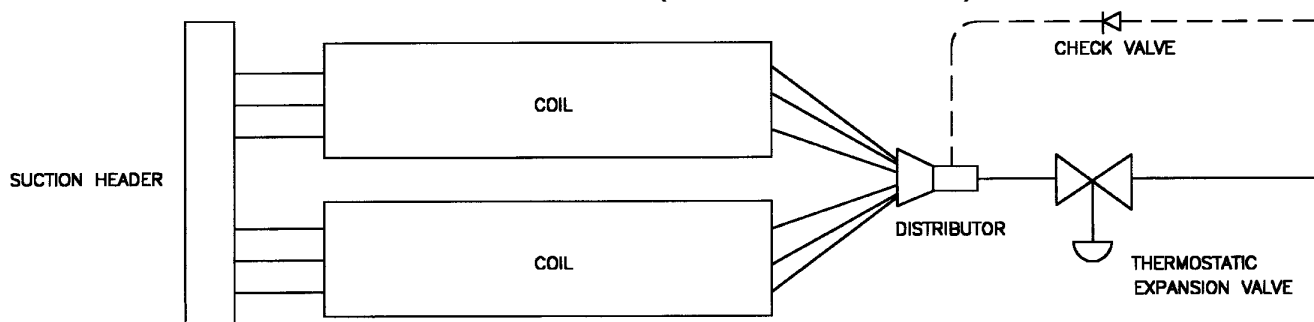

FIGURE 3

Models with Standard PSC Motors

Medium Temperature, 7 FPI, with standard PSC Motors

TEMP	FPI	# of Fans	Model TLV	Voltage	1 X EVAPORATOR		2 X EVAPORATOR	
					Defrost Kit	Fuse Package	Defrost Kit	Fuse Package
MEDIUM	7	1	060ED-S1B	115/1/60	DFK-01	FP-003	DFK-05	FP-007
			060ED-S2B	208-230/1/60	DFK-02	FP-004	DFK-06	FP-008
			090ED-S1B	115/1/60	DFK-01	FP-003	DFK-05	FP-007
			090ED-S2B	208-230/1/60	DFK-02	FP-004	DFK-06	FP-008
			120ED-S2B	208-230/1/60	DFK-02	FP-006	DFK-06	FP-015
		2	150ED-S2B	208-230/1/60	DFK-02	FP-006	DFK-06	FP-015
			180ED-S2B	208-230/1/60	DFK-02	FP-007	DFK-06	FP-010
			220ED-S2B	208-230/1/60	DFK-02	FP-007	DFK-06	FP-010
		3	270ED-S2B	208-230/1/60	DFK-02	FP-007	DFK-06	FP-010
			300ED-S2B	208-230/1/60	DFK-02	FP-007	DFK-06	FP-010
		4	340ED-S2B	208-230/1/60	DFK-04	FP-012	DFK-08	FP-017
			370ED-S2B	208-230/1/60	DFK-04	FP-012	DFK-08	FP-017

Models with Optional SMARTSPEED™ EC Motors

Medium Temperature, 7 FPI, with optional SMARTSPEED™ EC Motors

TEMP	FPI	# of Fans	Model TLV	Voltage	1 X EVAPORATOR		2 X EVAPORATOR	
					Defrost Kit	Fuse Package	Defrost Kit	Fuse Package
MEDIUM	7	1	060ED-S1B-D	115/1/60	DFK-01	FP-003	DFK-05	FP-007
			060ED-S2B-D	208-230/1/60	DFK-02	FP-004	DFK-06	FP-008
			090ED-S1B-D	115/1/60	DFK-01	FP-003	DFK-05	FP-007
			090ED-S2B-D	208-230/1/60	DFK-02	FP-004	DFK-06	FP-008
			120ED-S2B-D	208-230/1/60	DFK-02	FP-006	DFK-06	FP-015
		2	150ED-S2B-D	208-230/1/60	DFK-02	FP-006	DFK-06	FP-015
			180ED-S2B-D	208-230/1/60	DFK-02	FP-007	DFK-06	FP-010
			220ED-S2B-D	208-230/1/60	DFK-02	FP-007	DFK-06	FP-010
		3	270ED-S2B-D	208-230/1/60	DFK-02	FP-007	DFK-06	FP-010
			300ED-S2B-D	208-230/1/60	DFK-02	FP-007	DFK-06	FP-010
		4	340ED-S2B-D	208-230/1/60	DFK-04	FP-012	DFK-08	FP-017
			370ED-S2B-D	208-230/1/60	DFK-04	FP-012	DFK-08	FP-017

## Defrost Kits

Number of Evaps.	Kit Part Number	Description
1	<b>DFK-01</b>	Time Clock, HtrCont - 1x 40A (3P), FB 1x 30A (1P)
1	<b>DFK-02</b>	Time Clock, HtrCont - 1x 40A (3P), FB 1x 30A (2P)
1	<b>DFK-03</b>	Time Clock, HtrCont - 1x 40A (3P), FB 1x 30A (3P)
1	<b>DFK-04</b>	Time Clock, HtrCont - 1x 40A (3P), FB 1x 60A (2P)
2	<b>DFK-05</b>	Time Clock, HtrCont - 1x 40A (3P), FB 2x 30A (1P)
2	<b>DFK-06</b>	Time Clock, HtrCont - 1x 40A (3P), FB 2x 30A (2P)
2	<b>DFK-07</b>	Time Clock, HtrCont - 1x 40A (3P), FB 2x 30A (3P)
2	<b>DFK-08</b>	Time Clock, HtrCont - 1x 50A (3P), FB 2x 60A (2P)
2	<b>DFK-09</b>	Time Clock, HtrCont - 1x 50A (3P), FB 2x 30A (2P)
1	<b>DFK-10</b>	Time Clock, HtrCont - 1x 40A (3P), FanCont - 1x 40A (3P), FB 2x 30A (2P)
1	<b>DFK-11</b>	Time Clock, HtrCont - 1x 40A (3P), FanCont - 1x 40A (3P), FB 2x 30A (3P)
2	<b>DFK-12</b>	Time Clock, HtrCont - 1x 40A (3P), FanCont - 1x 40A (3P), FB 4x 30A (2P)
2	<b>DFK-13</b>	Time Clock, HtrCont - 1x 40A (3P), FanCont - 1x 40A (3P), FB 4x 30A (3P)
1	<b>DFK-14</b>	Time Clock, HtrCont - 1x 40A (3P), FanCont - 1x 40A (3P), FB 1x 30A (2P), FB 1x 30A (3P)
1	<b>DFK-15</b>	Time Clock, HtrCont - 1x40A (3P), FanCont - 1x 40A (3P), FB 1x 30A (2P), FB 1x 60A (2P)
1	<b>DFK-16</b>	Time Clock, HtrCont - 1x 40A (3P), FanCont - 1x 40A (3P), FB 1x 30A (2P), FB 1x 60A (3P)
1	<b>DFK-17</b>	Time Clock, HtrCont - 1x 40A (3P), FanCont - 1x 40A (3P), FB 1x 30A (3P), FB 1x 60A (3P)
2	<b>DFK-18</b>	Time Clock, HtrCont - 1x 40A (3P), FanCont - 1x 40A (3P), FB 2x 30A (2P), FB 2x 30A (3P)
2	<b>DFK-19</b>	Time Clock, HtrCont - 1x 50A (3P), FanCont - 1x 40A (3P), FB 4x 30A (2P)
2	<b>DFK-20</b>	Time Clock, HtrCont - 1x 50A (3P), FanCont - 1x 40A (3P), FB 4x 30A (3P)
1	<b>DFK-21</b>	Time Clock, HtrCont - 1x 50A (3P), FanCont - 1x 40A (3P), FB 1x 30A (2P), FB 1x 60A (2P)
1	<b>DFK-22</b>	Time Clock, HtrCont - 1x 50A (3P), FanCont - 1x 40A (3P), FB 1x 30A (3P), FB 1x 60A (3P)
2	<b>DFK-23</b>	Time Clock, HtrCont - 1x 50A (3P), FanCont - 1x 40A (3P), FB 2x 30A (2P), FB 2x 30A (3P)
2	<b>DFK-24</b>	Time Clock, HtrCont - 1x 50A (3P), FanCont - 1x 40A (3P), FB 2x 30A (3P), FB 2x 60A (3P)
1	<b>DFK-25</b>	Time Clock, HtrCont - 2x 40A (3P), FanCont - 1x 40A (3P), FB 1x 30A (2P), FB 2x 60A (2P)
1	<b>DFK-26</b>	Time Clock, HtrCont - 2x 40A (3P), FanCont - 1x 40A (3P), FB 1x 30A (3P), FB 2x 60A (3P)
2	<b>DFK-27</b>	Time Clock, HtrCont - 2x 40A (3P), FanCont - 1x 40A (3P), FB 2x 30A (2P), FB 2x 60A (2P)
2	<b>DFK-28</b>	Time Clock, HtrCont - 2x 40A (3P), FanCont - 1x 40A (3P), FB 2x 30A (2P), FB 2x 60A (3P)
2	<b>DFK-29</b>	Time Clock, HtrCont - 2x 40A (3P), FanCont - 1x 40A (3P), FB 2x 30A (3P), FB 2x 60A (3P)
2	<b>DFK-30</b>	Time Clock, HtrCont - 2x 40A (3P), FanCont - 1x 50A (3P), FB 2x 30A (2P), FB 2x 60A (3P)
1	<b>DFK-31</b>	Time Clock, HtrCont - 2x 50A (3P), FanCont - 1x 40A (3P), FB 1x 30A (3P), FB 2x 60A (3P)
2	<b>DFK-32</b>	Time Clock, HtrCont - 2x 50A (3P), FanCont - 1x 40A (3P), FB 2x 30A (2P), FB 2x 60A (2P)
2	<b>DFK-33</b>	Time Clock, HtrCont - 2x 50A (3P), FanCont - 1x 40A (3P), FB 2x 30A (3P), FB 2x 60A (3P)
2	<b>DFK-34</b>	Time Clock, HtrCont - 4x 40A (3P), FanCont - 1x 40A (3P), FB 2x 30A (2P), FB 4x 60A (2P)
2	<b>DFK-35</b>	Time Clock, HtrCont - 4x 40A (3P), FanCont - 1x 40A (3P), FB 2x 30A (3P), FB 4x 60A (3P)
2	<b>DFK-36</b>	Time Clock, HtrCont - 4x 40A (3P), FanCont - 1x 50A (3P), FB 2x 30A (2P), FB 4x 60A (2P)
2	<b>DFK-37</b>	Time Clock, HtrCont - 4x 40A (3P), FanCont - 1x 50A (3P), FB 2x 30A (3P), FB 4x 60A (3P)
2	<b>DFK-38</b>	Time Clock, HtrCont - 4x 50A (3P), FanCont - 1x 50A (3P), FB 2x 30A (3P), FB 4x 60A (3P)
1	<b>DFK-39</b>	Time Clock, HtrCont1 - 1x 40A (3P), HtrCont2 - 2x 50A (3P), FanCont - 1x 40A (3P), FB 4x 60A (3P)

NOTE: HtrCont = Heater Contactor, FanCont = Fan Contactor, FB = Fuse Block, (1P), (2P), (3P) = Number of Poles

**Fuse Packages**

Package Part Number	Description
FP-001	FUSES (1) 15AMP
FP-002	FUSES (1) 20AMP
FP-003	FUSES (1) 25AMP
FP-004	FUSES (2) 15AMP
FP-006	FUSES (2) 20AMP
FP-007	FUSES (2) 25AMP
FP-008	FUSES (4) 15AMP
FP-010	FUSES (4) 25AMP
FP-012	FUSES (2) 35AMP
FP-013	FUSES (3) 15AMP
FP-014	FUSES (3) 20AMP
FP-015	FUSES (4) 20AMP
FP-016	FUSES (4) 20AMP (6) 45AMP
FP-017	FUSES (4) 35AMP
FP-018	FUSES (6) 15AMP
FP-019	FUSES (6) 20AMP
FP-020	FUSES (2) 30AMP
FP-021	FUSES (4) 30AMP
FP-022	FUSES (8) 15AMP
FP-023	FUSES (2) 25AMP (3) 50AMP
FP-024	FUSES (2) 20AMP (3) 45AMP
FP-025	FUSES (6) 20AMP (6) 60AMP
FP-026	FUSES (6) 15AMP (12) 40AMP
FP-027	FUSES (6) 15AMP (6) 40AMP
FP-028	FUSES (6) 20AMP (12) 40AMP
FP-029	FUSES (6) 15AMP (6) 50AMP
FP-030	FUSES (6) 15AMP (6) 45AMP
FP-031	FUSES (6) 15AMP (6) 35AMP
FP-032	FUSES (6) 15AMP (6) 30AMP
FP-033	FUSES (6) 25AMP (12) 50AMP
FP-034	FUSES (6) 20AMP (12) 35AMP
FP-035	FUSES (4) 25AMP (6) 50AMP
FP-036	FUSES (6) 25AMP (12) 60AMP
FP-037	FUSES (6) 20AMP (12) 60AMP
FP-038	FUSES (6) 20AMP (12) 50AMP
FP-039	FUSES (6) 20AMP (12) 45AMP
FP-040	FUSES (6) 15AMP (12) 45AMP
FP-041	FUSES (5) 15AMP
FP-042	FUSES (10) 15AMP
FP-043	FUSES (3) 25AMP (6) 60AMP
FP-044	FUSES (3) 20AMP (6) 60AMP
FP-045	FUSES (3) 20AMP (6) 50AMP
FP-046	FUSES (3) 25AMP (6) 45AMP
FP-047	FUSES (3) 15AMP (6) 45AMP
FP-048	FUSES (4) 15AMP (4) 45AMP
FP-049	FUSES (4) 15AMP (4) 40AMP
FP-050	FUSES (3) 15AMP (3) 60AMP
FP-051	FUSES (4) 20AMP (6) 50AMP
FP-052	FUSES (4) 15AMP (6) 45AMP
FP-053	FUSES (4) 15AMP (6) 30AMP

Package Part Number	Description
FP-054	FUSES (3) 15AMP (6) 35AMP
FP-055	FUSES (2) 15AMP (2) 45AMP
FP-056	FUSES (2) 15AMP (2) 40AMP
FP-057	FUSES (2) 20AMP (3) 50AMP
FP-058	FUSES (2) 15AMP (3) 45AMP
FP-059	FUSES (2) 15AMP (3) 30AMP
FP-060	FUSES (2) 15AMP (2) 35AMP
FP-061	FUSES (2) 15AMP (2) 50AMP
FP-062	FUSES (2) 15AMP (2) 60AMP
FP-063	FUSES (2) 15AMP (3) 25AMP
FP-064	FUSES (2) 15AMP (3) 35AMP
FP-065	FUSES (2) 15AMP (3) 40AMP
FP-066	FUSES (2) 15AMP (3) 20AMP
FP-067	FUSES (4) 15AMP (4) 35AMP
FP-068	FUSES (4) 15AMP (4) 50AMP
FP-069	FUSES (4) 15AMP (4) 60AMP
FP-070	FUSES (4) 15AMP (6) 25AMP
FP-071	FUSES (4) 15AMP (6) 35AMP
FP-072	FUSES (4) 15AMP (6) 40AMP
FP-073	FUSES (4) 15AMP (6) 20AMP
FP-074	FUSES (3) 20AMP (3) 60AMP
FP-075	FUSES (3) 20AMP (6) 35AMP
FP-076	FUSES (3) 25AMP (6) 50AMP
FP-077	FUSES (3) 35AMP (9) 45AMP
FP-078	FUSES (3) 15AMP (3) 35AMP
FP-079	FUSES (3) 15AMP (3) 45AMP
FP-080	FUSES (3) 15AMP (3) 50AMP
FP-081	FUSES (3) 20AMP (6) 40AMP
FP-082	FUSES (3) 15AMP (3) 40AMP
FP-083	FUSES (3) 15AMP (6) 40AMP
FP-084	FUSES (6) 15AMP (6) 60AMP
FP-085	FUSES (6) 15AMP (12) 35AMP
FP-086	FUSES (3) 35AMP (3) 45AMP (6) 60AMP
FP-087	FUSES (4) 20AMP (4) 40AMP (4) 50AMP
FP-088	FUSES (4) 15AMP (4) 35AMP (4) 40AMP
FP-089	FUSES (2) 20AMP (2) 40AMP (2) 50AMP
FP-090	FUSES (2) 15AMP (2) 35AMP (2) 40AMP
FP-091	FUSES (2) 20AMP (2) 35AMP (2) 40AMP
FP-092	FUSES (2) 25AMP (2) 40AMP (2) 50AMP
FP-093	FUSES (4) 20AMP (4) 35AMP (4) 40AMP
FP-094	FUSES (6) 15AMP (6) 25AMP
FP-095	FUSES (3) 15AMP (3) 25AMP
FP-096	FUSES (3) 15AMP (3) 30AMP
FP-097	FUSES (4) 15AMP (4) 30AMP
FP-098	FUSES (4) 15AMP (4) 25AMP
FP-099	FUSES (4) 15AMP (4) 20AMP
FP-100	FUSES (2) 15AMP (2) 20AMP
FP-101	FUSES (2) 15AMP (2) 25AMP
FP-102	FUSES (2) 15AMP (2) 30AMP
FP-103	FUSES (4) 25AMP (4) 40AMP (4) 50AMP

NOTE: FUSES 30AMP and Below - Class CC Type, FUSES 35AMP and Above - Class J Type

## INSTALLATION

The installation and start-up of LV Evaporators should only be performed by qualified refrigeration mechanics.

This equipment should be installed in accordance with all applicable codes, ordinances and local by-laws.

## INSPECTION

Inspect all equipment before unpacking for visible signs of damage or loss. Check shipping list against material received to ensure shipment is complete.

**IMPORTANT:** Remember, you, the consignee, must make any claim necessary against the transportation company. Shipping damage or missing parts, when discovered at the outset, will prevent later unnecessary and costly delays.

**If damage or loss during transport is evident, make claim to carrier, as this will be their responsibility, not the manufacturer's.**

Should carton be damaged, but damage to equipment is not obvious, a claim should be filed for "concealed damage" with the carrier.

**IMPORTANT:** The electrical characteristics of the unit should be checked at this time to make sure they correspond to those ordered and to electrical power available at the job site.

Save all shipping papers, tags and instruction sheets for reference by installer and owner.

## APPLICATION

LV Unit Coolers are designed for use with a variety of popular refrigerants. At room temperatures above 34°F (1.1°C) (and evaporating temps no lower than 24°F (-4.4°C)) positive coil defrosting (Electric or Hot Gas) is not required. (The air flowing through the coil will accomplish the defrost). At room temperatures of 34°F (1.1°C) and below, positive defrosting is required (either Electric (ED) or Hot Gas (HE, RE, TE) in model nomenclature). These models require the use of (1) Time Clock or equivalent (to initiate and terminate the defrost cycle), and (2) Defrost Termination Control (to prevent unnecessary prolonged heating and steaming of the coil once all the ice and frost has melted), (3) Hot Gas models also utilize a Fan/Heater drain pan control.

The coil must not be exposed to any abnormal atmospheric or acidic environments. This may result in corrosion to the cabinet and possible coil failure (leaks). (Consult manufacturer for optional baked on phenolic protective coatings).

## LOCATION

The unit location in the room should be selected to ensure uniform air distribution throughout the entire space to be refrigerated. Be sure that the unit does not draw air in, or blow directly out, through an opened door and that the product does not obstruct the free circulation of air. Allow a minimum of 24" clearance at each end. LV Evaporators draw air through the fans and discharge air through both coils.

Consideration should be given to the coil location in order to minimize the piping run length to the condensing unit and floor drain.

## EXPANSION VALVE (TXV) SELECTION

All units require the use of an **externally equalized** expansion valve. (A 1/4" (6 mm) O.D. equalizer line has been provided on the coil) TX valves should **not** be selected strictly by their nominal ton rating. (This rating is based at a specific pressure differential and entering liquid temperature). Since applications will differ it is suggested the following selection procedure be followed.

1. Determine actual unit cooler BTUH or KW (thermal). The nominal rating is based at 10 °F T.D. (5 .5°C) (Room Temp. minus Evap. Temp.). Note that a higher / lower operating T.D. will increase / decrease this capacity rating by their direct ratio.
2. Determine the pressure drop across the valve by subtracting the suction (evaporating) pressure from the high side liquid pressure. Note: Also subtract the distributor pressure loss (use approx. 25 psig (1.1 bar) for R134a and 35 psig (2.4 bar) for R404A/R507/R22/R407A/R448A).
3. Estimate entering liquid temperature. Temperatures lower than 100°F (37.7°C) increase valve capacity ratings. Refer to valve manufacturer's specs for details.
4. Select valve from the valve manufacturer selection charts for the appropriate refrigerant, evaporating temp and pressure drop.
5. After following the manufacturer's installation instructions and after the room has reached the desired temperature the valve superheat should be checked. This will confirm that the evaporator is operating properly and performing to maximum efficiency. The superheat should be around 5 to 8 °F (2.7 to 4.4°C) for a 10 to 12°F (5.5 to 6.6°C) T.D. Too high or low a superheat will result in unsatisfactory system performance and possible compressor problems.

## NOZZLE INSTALLATION

All LV Evaporators have nozzles installed at factory. For nozzle selection refer to selection table. In case it is required to install the nozzle at some point in the future, the nozzle retainer clip (in distributor) must be removed before inserting nozzle. Re-install clip ensuring nozzle is properly in place.



Visit  
[www.-trp.com/esp](http://www.trp.com/esp)  
 for Quick Start Guide,  
 Operation Manual, etc

**MOUNTING**

Refer to dimensional drawing for recommended mounting arrangements. Formed mounting channels are provided for flush mounting to the ceiling. Ensure adequate clearance (at least 24" (600 mm)) is provided at each end (to enable access to the electrical and refig. compartments).

**Ensure that the ceiling is level since the drain pan has been sloped for drainage during the defrost cycle.**

**DRAIN LINE**

The drain line should be run from the drain connection, sloping at least 1/4" (6 mm) per foot. A trap in a warm area outside the room will allow proper draining through the tubing. Connection should be made to proper drainage facilities that comply with local regulations.

To prevent freeze-up when the temperature of the refrigerated space is 35 °F (1.7 °C) or lower, the drain line should be heated along its run inside the cold room. The heated drain line should be insulated. It is recommended that the heater be energized at all times. A heat input of 20 watts per foot in a 28°F (-2.2°C) room, is satisfactory. Drain line heaters are not required for constant room temperature above 35°F (1.6°C).

**Ensure that the drain line has sufficient slope for proper drainage (prevention of ice build up/blockage in pan).**

**PIPING**

Refrigerant line sizes are important and **may not** be the same size as the coil connections. Consult "Recommended refrigerant line sizes" charts in any standard reference book for proper line sizing.

Refrigerant piping and control system should be designed to prevent possible liquid slugging (from oil or refrigerant) of the compressors on start-up after the defrost cycle. On Hot Gas Defrost Systems the suction accumulator should be at least 2.5 times the coils operating charge.

See Dimensional data for line locations. For Reverse Cycle and Hot Gas models and 3-Pipe - see fig. 2 & 3 respectively on page 12 for typical unit piping. These models include a check valve (unmounted) packaged along with the nozzle in the refig. connection compartment end panel.

**WIRING**

Wire system in accordance with governing standards and local codes. See data and wiring diagrams on pages 6 to 10 for wiring arrangement. Electrical wiring is to be sized in accordance with minimum circuit ampacity rating (MCA).

For ease of identifying the proper wiring terminal, unit wiring is color coded and terminal block connections are identified.

**SYSTEM CHECK****Before Start-Up:**

1. All wiring should be in accordance with local codes.
2. Refrigerant lines should be properly sized.
3. Off cycle defrost and electric defrost systems preferably must include a liquid line solenoid valve and suction accumulator.
4. Thorough evacuation and, dehydration has been performed.
5. The suction, discharge, and receiver service valves must be open.
6. The system preferably must include a liquid line drier moisture indicator and suction filter.
7. Pour enough water into the drain pan to allow a good check on drainage and seal the trap.

**After Start-Up:**

1. Check the oil level to be sure the oil charge is correct.
2. On initial start up the fans do not start until coil temperature is pulled down to approximately 35°F (1.7°C) on the hot gas coil. Also, it is normal for the fans to cycle a few times until the room temperature is pulled down.
3. Fan/Heater control and defrost termination control is factory installed for reverse cycle defrost operation. Refer to Fig. 1 on page 14.
4. If coil is to be used for 3-pipe (bypass) Hot Gas Defrost, Fan/Heater must be moved from suction line to hot gas inlet line and the defrost termination control moved to the suction line. Refer to Fig. 1 on page 14.
5. In general, evaporators running with a TD of 10°F should have a superheat reading of 5 to 8 °F (2.7 to 4.4°C). For evaporators with a higher TD, the superheat should be 8 to 12°F (4.4 to 6.6 °C).
6. Heavy moisture loads are usually encountered when starting the system for the first time. This will cause a rapid build-up of frost on the unit cooler. During the initial pull down, we suggest that the frost build-up be watched and defrosted manually as required. This may be done by rotating the inner dial on the timer until the pin in the outer dial is directly opposite the timer pointer. (Paragon 8145-20 Timer by others).
7. Observe that the system goes through at least one complete DEFROST CYCLE.

**MAINTENANCE**

The unit should be periodically inspected for any dirt or build-up on the fin surface and cleaned if necessary with a soft whisk or brush. Also ensure coils inner and outer drain pans do not have any ice build-up from improper defrost operation. When replacing heater elements first remove heater retainer brackets and heater clips.







System	
Model Number	Date of Start-Up
Serial Number	Service Contractor
Refrigerant	Phone
Electrical Supply	E-Mail



**PRODUCT SUPPORT**

*web:* [www.t-rp.com/tlv](http://www.t-rp.com/tlv)  
*email:* [evaps@t-rp.com](mailto:evaps@t-rp.com)  
*call:* 1-844-893-3222 x520



**TROUBLESHOOTING**

*email:* [troubleshooting@t-rp.com](mailto:troubleshooting@t-rp.com)  
*call:* 1-844-893-3222 x529



**SERVICE PARTS**

*web:* [www.t-rp.com/parts](http://www.t-rp.com/parts)  
*email:* [parts@t-rp.com](mailto:parts@t-rp.com)  
*call:* 1-844-893-3222 x520



**WARRANTY**

*web:* [www.t-rp.com/warranty](http://www.t-rp.com/warranty)  
*email:* [warranty@t-rp.com](mailto:warranty@t-rp.com)  
*call:* 1-844-893-3222 x501



**ORDERS**

*email:* [orders@t-rp.com](mailto:orders@t-rp.com)  
*call:* 1-844-893-3222 x501



**SHIPPING**

*email:* [shipping@t-rp.com](mailto:shipping@t-rp.com)  
*call:* 1-844-893-3222 x503

**HOW CAN WE HELP YOU?**  
visit [www.t-rp.com/contact](http://www.t-rp.com/contact)

# “AS BUILT” SERVICE PARTS LIST

Service Parts List  
Label  
To Be Attached  
*HERE*



Trenton Refrigeration  
Brantford, ON • Longview, TX  
1-800-463-9517 info@t-rp.com www.t-rp.com

